



USERS GUIDE INFOCUS LIGHTPRO VISTA II, GENESIS III, GENESIS IV, ORBITAL SERIES

InFocus

REGULATORY MODE	SERIES NAME	LENS TYPE/ RESOLUTION	SVGA	XGA	WXGA	1080P	4K
P122	INFOCUS LIGHTPRO VISTA II	STANDARD THROW	–	IN0044SL	IN0046SL	IN0048SL	–
P123	INFOCUS LIGHTPRO VISTA II	SHORT THROW	–	IN0044ST	IN0046ST	IN0048ST	–
P124	INFOCUS LIGHTPRO GENESIS III	STANDARD THROW	IN0002SL	IN0004SL	IN0006SL	–	–
P125	INFOCUS LIGHTPRO GENESIS IV	STANDARD THROW	IN0022SL	IN0024SL	IN0026SL	IN0028SL	–
P126	INFOCUS LIGHTPRO GENESIS IV	SHORT THROW	–	IN0024ST	IN0026ST	–	–
P134	INFOCUS LIGHTPRO ORBITAL	STANDARD THROW	–	–	–	–	IN0061SL



TABLE OF CONTENTS

1. ABOUT THIS GUIDE.....	4
1.1 DESCRIPTION OF THE USER	4
1.2 CONVENTIONS USED IN THIS GUIDE.....	4
1.3 EXPLANATION OF SAFETY WARNINGS	4
1.4 RETAINING INSTRUCTIONS	4
1.5 OBTAINING DOCUMENTATION AND INFORMATION	5
1.6 DOCUMENTATION FEEDBACK.....	5
1.7 SUPPORT AND SERVICE	5
2. PRODUCT DESCRIPTION.....	6
2.1 FEATURES	6
2.2 INTENDED USE AND REASONABLY FORESEEABLE MISUSE	8
2.3 PRODUCT ELEMENTS.....	8
2.3.1 FRONT	8
2.3.2 RIGHT SIDE	10
2.3.3 LEFT SIDE	11
2.3.4 TOP	13
2.3.5 BACK	14
3. SAFETY	16
4. UNPACKING AND INSTALLING	17
4.1 PACKAGING CONTENTS	17
4.2 INSTALLATION INSTRUCTIONS	17
4.3 PLACEMENT AND DISTANCE FROM THE SCREEN.....	17
4.3.1 PROJECTION DISTANCE AND SCREEN SIZE.....	17
4.4 CLEARANCE.....	24
4.5 CEILING MOUNT	25
4.6 MOUNTING HOLE DIAGRAM	26
5. ADJUSTING	27
5.1 ADJUSTING THE IMAGE HEIGHT AND TILT	27
5.2 ADJUSTING THE ZOOM, LENS SHIFT AND FOCUS.....	27
5.3 ADJUSTING THE VERTICAL AND HORIZONTAL KEYSTONE	27
6. CONNECTING	29
6.1 CONNECTION DIAGRAM	29
7. USING	30
7.1 LEDS	30
7.2 KEYPAD.....	30
7.3 REMOTE CONTROL	31
7.3.1 INSTALLING BATTERIES IN THE REMOTE CONTROL	32
7.3.2 REMOTE CONTROL IR CODES	33
7.4 REMOTE CONTROL EFFECTIVE RANGE	33
7.5 TURNING THE PROJECTOR ON	34
7.6 SELECTING A INPUT SOURCE.....	34
7.7 TURNING THE PROJECTOR TO STANDBY MODE	34
7.8 VIEWING 3D CONTENT	35
7.8.1 PHOTOSENSITIVE SEIZURE WARNING AND OTHER HEALTH RISKS	35
7.8.2 ENABELING 3D MODE	36
7.8.3 ENABLING AUTO 3D MODE	36

8. USING THE ON SCREEN DISPLAY (OSD)	37
8.1 SELECTING THE LANGUAGE FOR THE ON SCREEN MENU	37
8.2 SELECTING A DISPLAY MODE.....	37
8.3 ADJUSTING THE IMAGE COLOUR AND TEMPERATURE	38
8.4 ADJUSTING THE SHARPNESS OF THE IMAGE.....	38
8.5 MAGNIFYING THE IMAGE.....	38
8.6 SELECTING AN ASPECT RATIO	38
8.7 ADJUSTING THE BRIGHTNESS	38
8.8 ENABELING ECO MODE	39
8.9 ENABLING CLOSED CAPTIONS	39
8.10 DISPLAYING A TEST PATTERN	39
8.11 PREVENTING UNAUTHORIZED USE.....	39
8.12 CHANGING THE PASSWORD.....	39
8.13 CONTROLLING THE PROJECTOR FROM A WEB BROWSER	40
8.14 DIRECTLY CONNECTING A COMPUTER TO THE PROJECTOR	45
9. CLEANING	45
9.1 CLEANING THE LENS.....	45
9.2 CLEANING THE CASE	45
9.3 CLEANING THE AIR VENTS	45
10. SANITATION	45
11. DISPOSAL	46
11.1 DISPOSAL OF ELECTRICAL COMPONENTS	46
11.2 DISPOSAL OF PACKAGING WASTE	46
12. TROUBLESHOOTING	47
12.1 LED INDICATOR LIGHTS	47
12.2 SOLVING ON / OFF ISSUES	47
12.3 SOLVING IMAGE ISSUES	47
12.4 SOLVING VIDEO, AUDIO AND REMOTE CONTROL ISSUES	48
12.5 SERVICING.....	48
13. ADDITIONAL INFORMATION	49
13.1 RS232 PIN ASSIGNMENTS.....	49
13.2 RS232 PROTOCOL FUNCTION LIST	49
13.3 SUPPORTED RESOLUTIONS AND REFRESH RATES	49
13.4 ON SCREEN DISPLAY (OSD) MENU TREE	51
14. SPECIFICATIONS	59
14.1 VISTA II, P122 & P123, SPECIFICATIONS.....	59
14.2 GENESIS III, P124, SPECIFICATIONS	61
14.3 GENESIS IV, P125 & P126, SPECIFICATIONS	63
14.4 ORBITAL, P134, SPECIFICATIONS	65
15. PRODUCT COMPLIANCE	67
15.1 FOR USERS IN THE UNITED STATES	67
15.2 FOR USERS IN CANADA.....	67
15.3 FOR USERS IN EUROPEAN UNION	68
15.4 FOR USERS IN THE UNITED KINGDON AND NORTHERN IRELAND	68
15.5 FOR USERS IN RUSSIA	69

1. ABOUT THIS GUIDE

1.1 DESCRIPTION OF THE USER

This document is intended for anyone who will install, setup, or use the projector.

1.2 CONVENTIONS USED IN THIS GUIDE

The following style conventions are used in this document:

Bold

- Names of product elements, commands, options, and programs.
- Names of interface elements (such windows, dialog boxes, buttons, fields, and menus).
- Interface elements the user selects, clicks, taps, or types.

Italic

- Publication titles.
- Emphasis (for example, a new term).

1.3 EXPLANATION OF SAFETY WARNINGS



WARNING

"WARNING" indicates a hazard with a medium to high level of risk which, could result in death or serious injury.



ATTENTION

"ATTENTION" indicates a hazard with a low level of risk which, if not avoided, could result in minor or moderate injury.



INFORMATION

"INFORMATION" indicates information considered important, but not hazard-related.

1.4 RETAINING INSTRUCTIONS

Keep all safety information and instructions for future reference and pass them on to subsequent users of the product.



WARNING

Ensure that each person who uses the product has read and understood this guide and its safety instructions before using this product. Failure to do so can result in serious injury or death.



ATTENTION

Follow all the instructions. This will avoid fire, explosions, electric shocks, or other hazards that may result in damage to property and/or severe or fatal injuries.



INFORMATION

The manufacturer is not liable for cases of material damage or personal injury caused by incorrect handling or non-compliance with the safety instructions. In such cases, the warranty will be voided.

1.5 OBTAINING DOCUMENTATION AND INFORMATION

The latest version of this document can be obtained by visiting:

- <https://infocus.com/product/infocus-vista-ii-series/>
- <https://infocus.com/product/infocus-genesis-iii/>
- <https://infocus.com/product/infocus-genesis-iv/>
- <https://infocus.com/product/orbital/>

1.6 DOCUMENTATION FEEDBACK

If you are reading product documentation on the internet, any comments can be submitted [Here](#). We appreciate your comments.

1.7 SUPPORT AND SERVICE

Please contact the support team in your region for technical and product support. Alternatively, you may contact your local distributor if you are in Asia or Australia.

Americas

Monday – Friday
6am – 5pm PST

-  +1 877-388-8360
-  support@infocus.com
-  infocus.com/support

Europe, Middle East & Africa

Monday – Friday
8am – 5pm CET

-  eusupport@infocus.com
-  infocus.com/support

Asia Pacific

Monday – Friday
8am – 5pm ICT

-  apsupport@infocus.com
-  infocus.com/support

2. PRODUCT DESCRIPTION

2.1 FEATURES

	GENESIS III			GENESIS IV				VISTA II				ORBITAL				
	P124			P125		P126	P122		P123		P134					
	IN0002SL	IN0004SL	IN0006SL	IN0022SP	IN0024SL	IN0026SL	IN0028SL	IN0024ST	IN0026ST	IN0044SL	IN0046SL	IN0048SL	IN0044ST	IN0046ST	IN0048ST	IN0061SL
Nine Picture Modes including DICOM Simulation, User Definable and ISF Night & Day	●	●	●	●	●	●	●	●	●	●	●	●	●	●	●	●
Seven Wall Colour Modes	●	●	●	●	●	●	●	●	●	●	●	●	●	●	●	●
Brightness, Sharpness, Contrast, Colour, Tint, Gamma Adjustment Settings	●	●	●	●	●	●	●	●	●	●	●	●	●	●	●	●
10 Step BrilliantColor Implementation	●	●	●	●	●	●	●	●	●	●	●	●	●	●	●	●
Individual Hue, Saturation and Gain Adjustments for RGB, C, M, Y,W	●	●	●	●	●	●	●	●	●	●	●	●	●	●	●	●
RGB Gain/Bias Adjustments	●	●	●	●	●	●	●	●	●	●	●	●	●	●	●	●
Five Colour Space Adjustment Settings	●	●	●	●	●	●	●	●	●	●	●	●	●	●	●	●
White and Black Level Adjustments	●	●	●	●	●	●	●	●	●	●	●	●	●	●	●	●
IRE and Signal Settings and Adjustments	●	●	●	●	●	●	●	●	●	●	●	●	●	●	●	●
Aspect Ratio Format Settings	●	●	●	●	●	●	●	●	●	●	●	●	●	●	●	●
4:3	●	●	●	●	●	●	●	●	●	●	●	●	●	●	●	●
16:9	●	●	●	●	●	●	●	●	●	●	●	●	●	●	●	●
16:10	●	●	●	●	●	●	●	●	●	●	●	●	●	●	●	●
Letter Box	●	●	●	●	●	●	●	●	●	●	●	●	●	●	●	●
Native	●	●	●	●	●	●	●	●	●	●	●	●	●	●	●	●
Auto	●	●	●	●	●	●	●	●	●	●	●	●	●	●	●	●
Digital Edge Masking	●	●	●	●	●	●	●	●	●	●	●	●	●	●	●	●
Digital Image Shift - Horizontal & Vertical	●	●	●	●	●	●	●	●	●	●	●	●	●	●	●	●
Digital Zoom	●	●	●	●	●	●	●	●	●	●	●	●	●	●	●	●
Vertical Keystone Adjustment	●	●	●	●	●	●	●	●	●	●	●	●	●	●	●	●
3D Activation, DLP - Link Settings & Formats	●	●	●	●	●	●	●	●	●	●	●	●	●	●	●	●
3D Sync Invert	●	●	●	●	●	●	●	●	●	●	●	●	●	●	●	●
2D to 3D Setting	●	●	●	●	●	●	●	●	●	●	●	●	●	●	●	●
Enhanced Low Latency Gaming Mode	●	●	●	●	●	●	●	●	●	●	●	●	●	●	●	●
Picture Mode Lock	●	●	●	●	●	●	●	●	●	●	●	●	●	●	●	●
27 Selectable OSD Languages	●	●	●	●	●	●	●	●	●	●	●	●	●	●	●	●
Projection Modes - Front, Rear, Front Ceiling, Rear Ceiling OSD Menu Positioning	●	●	●	●	●	●	●	●	●	●	●	●	●	●	●	●
Screen Type - Aspect Ratio Locking 16:10	●	●	●	●	●	●	●	●	●	●	●	●	●	●	●	●
Screen Type - Aspect Ratio Locking 16:9	●	●	●	●	●	●	●	●	●	●	●	●	●	●	●	●
Security On/Off Setting	●	●	●	●	●	●	●	●	●	●	●	●	●	●	●	●
Security Timer	●	●	●	●	●	●	●	●	●	●	●	●	●	●	●	●

	GENESIS III			GENESIS IV						VISTA II				ORBITAL		
	P124			P125			P126			P122		P123		P134		
	IN002SL	IN004SL	IN006SL	IN002SP	IN0024SL	IN0026SL	IN0028SL	IN0024ST	IN0026ST	IN0044SL	IN0046SL	IN0048SL	IN0044ST	IN0046ST	IN0048ST	IN0061SL
Security Password Selector	<input type="checkbox"/>	<input type="checkbox"/>	<input type="checkbox"/>	<input type="checkbox"/>	<input type="checkbox"/>	<input type="checkbox"/>	<input type="checkbox"/>	<input type="checkbox"/>	<input type="checkbox"/>	<input type="checkbox"/>	<input type="checkbox"/>	<input type="checkbox"/>	<input type="checkbox"/>	<input type="checkbox"/>	<input type="checkbox"/>	<input type="checkbox"/>
Assignable Project ID Number	<input checked="" type="checkbox"/>	<input checked="" type="checkbox"/>	<input checked="" type="checkbox"/>	<input type="checkbox"/>	<input type="checkbox"/>	<input type="checkbox"/>	<input type="checkbox"/>	<input type="checkbox"/>	<input type="checkbox"/>	<input type="checkbox"/>	<input type="checkbox"/>	<input type="checkbox"/>	<input type="checkbox"/>	<input type="checkbox"/>	<input type="checkbox"/>	<input type="checkbox"/>
Audio Input and Volume Settings	<input type="checkbox"/>	<input type="checkbox"/>	<input type="checkbox"/>	<input type="checkbox"/>	<input type="checkbox"/>	<input type="checkbox"/>	<input type="checkbox"/>	<input type="checkbox"/>	<input type="checkbox"/>	<input type="checkbox"/>	<input type="checkbox"/>	<input type="checkbox"/>	<input type="checkbox"/>	<input type="checkbox"/>	<input type="checkbox"/>	<input type="checkbox"/>
HDMI Link Activation and Settings	<input type="checkbox"/>	<input type="checkbox"/>	<input type="checkbox"/>	<input type="checkbox"/>	<input type="checkbox"/>	<input type="checkbox"/>	<input type="checkbox"/>	<input type="checkbox"/>	<input type="checkbox"/>	<input type="checkbox"/>	<input type="checkbox"/>	<input type="checkbox"/>	<input type="checkbox"/>	<input type="checkbox"/>	<input type="checkbox"/>	<input type="checkbox"/>
Startup Logo Removal and Background Colour	<input type="checkbox"/>	<input type="checkbox"/>	<input type="checkbox"/>	<input type="checkbox"/>	<input type="checkbox"/>	<input type="checkbox"/>	<input type="checkbox"/>	<input type="checkbox"/>	<input type="checkbox"/>	<input type="checkbox"/>	<input type="checkbox"/>	<input type="checkbox"/>	<input type="checkbox"/>	<input type="checkbox"/>	<input type="checkbox"/>	<input type="checkbox"/>
Selector Projector Information Messaging Override	<input type="checkbox"/>	<input type="checkbox"/>	<input type="checkbox"/>	<input type="checkbox"/>	<input type="checkbox"/>	<input type="checkbox"/>	<input type="checkbox"/>	<input type="checkbox"/>	<input type="checkbox"/>	<input type="checkbox"/>	<input type="checkbox"/>	<input type="checkbox"/>	<input type="checkbox"/>	<input type="checkbox"/>	<input type="checkbox"/>	<input type="checkbox"/>
Input Source Lock Auto Source Setting High Altitude Setting Keypad Lock Setting Built in Test Patterns IR Fraction Setting	<input type="checkbox"/>	<input type="checkbox"/>	<input type="checkbox"/>	<input type="checkbox"/>	<input type="checkbox"/>	<input type="checkbox"/>	<input type="checkbox"/>	<input type="checkbox"/>	<input type="checkbox"/>	<input type="checkbox"/>	<input type="checkbox"/>	<input type="checkbox"/>	<input type="checkbox"/>	<input type="checkbox"/>	<input type="checkbox"/>	<input type="checkbox"/>
15 user presets with single key activation Direct Power On Setting	<input type="checkbox"/>	<input type="checkbox"/>	<input type="checkbox"/>	<input type="checkbox"/>	<input type="checkbox"/>	<input type="checkbox"/>	<input type="checkbox"/>	<input type="checkbox"/>	<input type="checkbox"/>	<input type="checkbox"/>	<input type="checkbox"/>	<input type="checkbox"/>	<input type="checkbox"/>	<input type="checkbox"/>	<input type="checkbox"/>	<input type="checkbox"/>
Signal Power On Setting	<input type="checkbox"/>	<input type="checkbox"/>	<input type="checkbox"/>	<input type="checkbox"/>	<input type="checkbox"/>	<input type="checkbox"/>	<input type="checkbox"/>	<input type="checkbox"/>	<input type="checkbox"/>	<input type="checkbox"/>	<input type="checkbox"/>	<input type="checkbox"/>	<input type="checkbox"/>	<input type="checkbox"/>	<input type="checkbox"/>	<input type="checkbox"/>
Auto Power Off Setting	<input type="checkbox"/>	<input type="checkbox"/>	<input type="checkbox"/>	<input type="checkbox"/>	<input type="checkbox"/>	<input type="checkbox"/>	<input type="checkbox"/>	<input type="checkbox"/>	<input type="checkbox"/>	<input type="checkbox"/>	<input type="checkbox"/>	<input type="checkbox"/>	<input type="checkbox"/>	<input type="checkbox"/>	<input type="checkbox"/>	<input type="checkbox"/>
Sleep Timer Setting	<input type="checkbox"/>	<input type="checkbox"/>	<input type="checkbox"/>	<input type="checkbox"/>	<input type="checkbox"/>	<input type="checkbox"/>	<input type="checkbox"/>	<input type="checkbox"/>	<input type="checkbox"/>	<input type="checkbox"/>	<input type="checkbox"/>	<input type="checkbox"/>	<input type="checkbox"/>	<input type="checkbox"/>	<input type="checkbox"/>	<input type="checkbox"/>
Quick Resume Setting	<input type="checkbox"/>	<input type="checkbox"/>	<input type="checkbox"/>	<input type="checkbox"/>	<input type="checkbox"/>	<input type="checkbox"/>	<input type="checkbox"/>	<input type="checkbox"/>	<input type="checkbox"/>	<input type="checkbox"/>	<input type="checkbox"/>	<input type="checkbox"/>	<input type="checkbox"/>	<input type="checkbox"/>	<input type="checkbox"/>	<input type="checkbox"/>
VGA Out Standby Setting	<input checked="" type="checkbox"/>	<input checked="" type="checkbox"/>	<input checked="" type="checkbox"/>	<input type="checkbox"/>	<input type="checkbox"/>	<input type="checkbox"/>	<input type="checkbox"/>	<input type="checkbox"/>	<input type="checkbox"/>	<input type="checkbox"/>	<input type="checkbox"/>	<input type="checkbox"/>	<input type="checkbox"/>	<input type="checkbox"/>	<input type="checkbox"/>	<input type="checkbox"/>
USB-A Power Setting	<input type="checkbox"/>	<input type="checkbox"/>	<input type="checkbox"/>	<input type="checkbox"/>	<input type="checkbox"/>	<input type="checkbox"/>	<input type="checkbox"/>	<input type="checkbox"/>	<input type="checkbox"/>	<input type="checkbox"/>	<input type="checkbox"/>	<input type="checkbox"/>	<input type="checkbox"/>	<input type="checkbox"/>	<input type="checkbox"/>	<input type="checkbox"/>
Lamp Usage Reminder Setting	<input type="checkbox"/>	<input type="checkbox"/>	<input type="checkbox"/>	<input type="checkbox"/>	<input type="checkbox"/>	<input type="checkbox"/>	<input type="checkbox"/>	<input type="checkbox"/>	<input type="checkbox"/>	<input type="checkbox"/>	<input type="checkbox"/>	<input type="checkbox"/>	<input type="checkbox"/>	<input type="checkbox"/>	<input type="checkbox"/>	<input type="checkbox"/>
Lamp Brightness Mode	<input type="checkbox"/>	<input type="checkbox"/>	<input type="checkbox"/>	<input type="checkbox"/>	<input type="checkbox"/>	<input type="checkbox"/>	<input type="checkbox"/>	<input type="checkbox"/>	<input type="checkbox"/>	<input type="checkbox"/>	<input type="checkbox"/>	<input type="checkbox"/>	<input type="checkbox"/>	<input type="checkbox"/>	<input type="checkbox"/>	<input type="checkbox"/>
Projector Information Table	<input type="checkbox"/>	<input type="checkbox"/>	<input type="checkbox"/>	<input type="checkbox"/>	<input type="checkbox"/>	<input type="checkbox"/>	<input type="checkbox"/>	<input type="checkbox"/>	<input type="checkbox"/>	<input type="checkbox"/>	<input type="checkbox"/>	<input type="checkbox"/>	<input type="checkbox"/>	<input type="checkbox"/>	<input type="checkbox"/>	<input type="checkbox"/>
24/7 Operation	<input type="checkbox"/>	<input type="checkbox"/>	<input type="checkbox"/>	<input type="checkbox"/>	<input type="checkbox"/>	<input type="checkbox"/>	<input type="checkbox"/>	<input type="checkbox"/>	<input type="checkbox"/>	<input type="checkbox"/>	<input type="checkbox"/>	<input type="checkbox"/>	<input type="checkbox"/>	<input type="checkbox"/>	<input type="checkbox"/>	<input type="checkbox"/>
Waveform Lamp Colour Enhancement AV Mute	<input type="checkbox"/>	<input type="checkbox"/>	<input type="checkbox"/>	<input type="checkbox"/>	<input type="checkbox"/>	<input type="checkbox"/>	<input type="checkbox"/>	<input type="checkbox"/>	<input type="checkbox"/>	<input type="checkbox"/>	<input type="checkbox"/>	<input type="checkbox"/>	<input type="checkbox"/>	<input type="checkbox"/>	<input type="checkbox"/>	<input type="checkbox"/>
AV Mute	<input type="checkbox"/>	<input type="checkbox"/>	<input type="checkbox"/>	<input type="checkbox"/>	<input type="checkbox"/>	<input type="checkbox"/>	<input type="checkbox"/>	<input type="checkbox"/>	<input type="checkbox"/>	<input type="checkbox"/>	<input type="checkbox"/>	<input type="checkbox"/>	<input type="checkbox"/>	<input type="checkbox"/>	<input type="checkbox"/>	<input type="checkbox"/>
Crestron Connect Certified	<input checked="" type="checkbox"/>	<input checked="" type="checkbox"/>	<input checked="" type="checkbox"/>	<input checked="" type="checkbox"/>	<input checked="" type="checkbox"/>	<input checked="" type="checkbox"/>	<input checked="" type="checkbox"/>	<input checked="" type="checkbox"/>	<input type="checkbox"/>	<input type="checkbox"/>	<input type="checkbox"/>	<input type="checkbox"/>	<input type="checkbox"/>	<input type="checkbox"/>	<input type="checkbox"/>	<input type="checkbox"/>

2.2 INTENDED USE AND REASONABLY FORESEEABLE MISUSE

The product may only be used in accordance with the instructions described in this guide. Any use other than those described in this guide is considered non-intended use and will void the warranty.

The ambient operating environment should be free of airborne smoke, grease, oil, and other contaminants that can affect the operation or performance of the projector.



WARNING

Do not use the product near water or moisture. Do not expose the product to rain, steam or condensation to reduce the risk of fire or electric shock.

2.3 PRODUCT ELEMENTS

2.3.1 FRONT

a)



REGULATORY MODEL	SERIES NAME	LENS TYPE/ RESOLUTION	SVGA	XGA	WXGA	1080P
P122	INFOCUS LIGHTPRO VISTA II	STANDARD THROW	-	IN0044SL	IN0046SL	IN0048SL
P124	INFOCUS LIGHTPRO GENESIS III	STANDARD THROW	IN0002SL	IN0004SL	IN0006SL	-
P125	INFOCUS LIGHTPRO GENESIS IV	STANDARD THROW	IN0022SL	IN0024SL	IN0026SL	IN0028SL

b)



REGULATORY MODEL	SERIES NAME	LENS TYPE/ RESOLUTION	SVGA	XGA	WXGA	1080P
P123	INFOCUS LIGHTPRO VISTA II	SHORT THROW	-	IN00445T	IN00465T	IN00485T
P126	INFOCUS LIGHTPRO GENESIS IV	SHORT THROW	-	IN00245T	IN00265T	-

c)



REGULATORY MODEL	SERIES NAME	LENS TYPE/ RESOLUTION	4K
P134	INFOCUS LIGHTPRO ORBITAL	STANDARD THROW	IN0061SL

2.3.2 RIGHT SIDE

a)

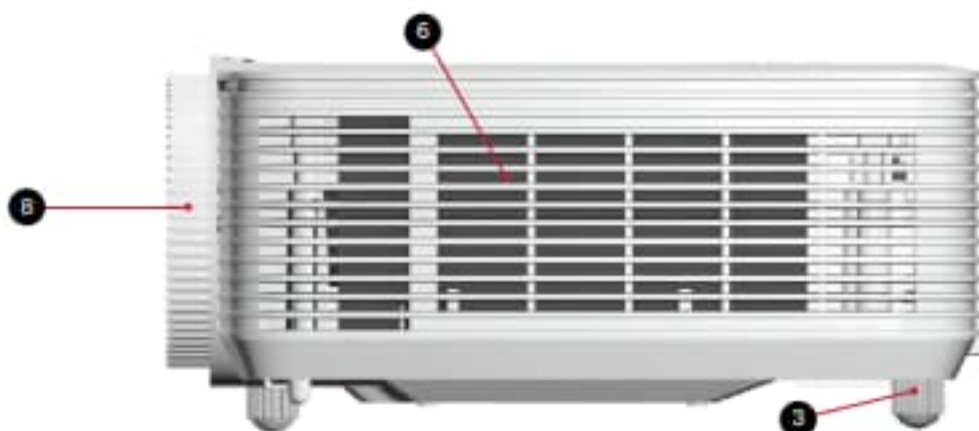

REGULATORY MODEL	SERIES NAME	LENS TYPE/ RESOLUTION	SVGA	XGA	WXGA	1080P
P122	INFOCUS LIGHTPRO VISTA II	STANDARD THROW	-	IN00445L	IN00465L	IN00485L
P124	INFOCUS LIGHTPRO GENESIS III	STANDARD THROW	IN00025L	IN00045L	IN00065L	-
P125	INFOCUS LIGHTPRO GENESIS IV	STANDARD THROW	IN00225L	IN00245L	IN00265L	IN00285L

b)

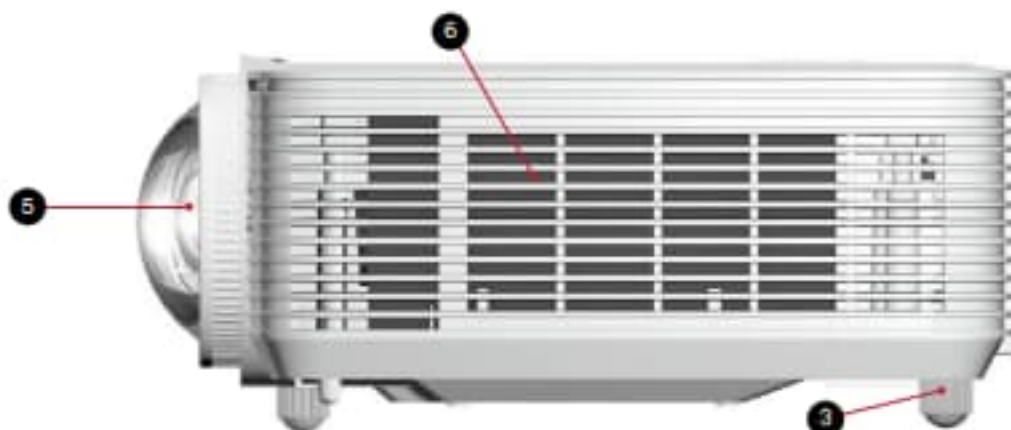

REGULATORY MODEL	SERIES NAME	LENS TYPE/ RESOLUTION	SVGA	XGA	WXGA	1080P
P123	INFOCUS LIGHTPRO VISTA II	SHORT THROW	-	IN00445T	IN00465T	IN00485T
P126	INFOCUS LIGHTPRO GENESIS IV	SHORT THROW	-	IN00245T	IN00265T	-

c)

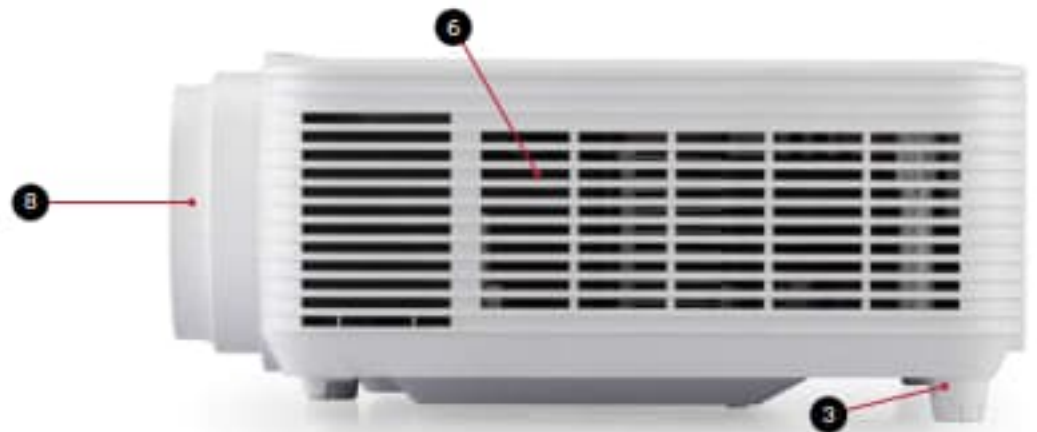

REGULATORY MODEL	SERIES NAME	LENS TYPE/ RESOLUTION	4K
P134	INFOCUS LIGHTPRO ORBITAL	STANDARD THROW	IN0061SL

2.3.3 LEFT SIDE

a)

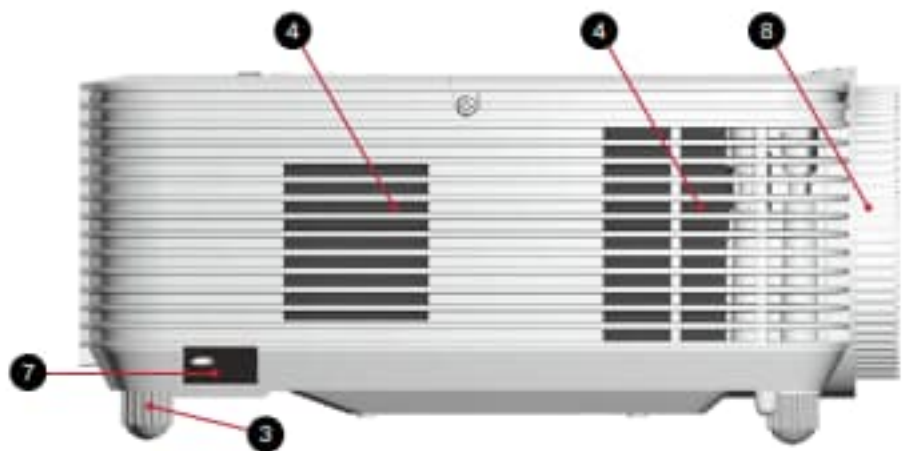

REGULATORY MODEL	SERIES NAME	LENS TYPE/ RESOLUTION	SVGA	XGA	WXGA	1080P
P122	INFOCUS LIGHTPRO VISTA II	STANDARD THROW	-	IN0044SL	IN0046SL	IN0048SL
P124	INFOCUS LIGHTPRO GENESIS III	STANDARD THROW	IN0002SL	IN0004SL	IN0006SL	-
P125	INFOCUS LIGHTPRO GENESIS IV	STANDARD THROW	IN0022SL	IN0024SL	IN0026SL	IN0028SL

b)

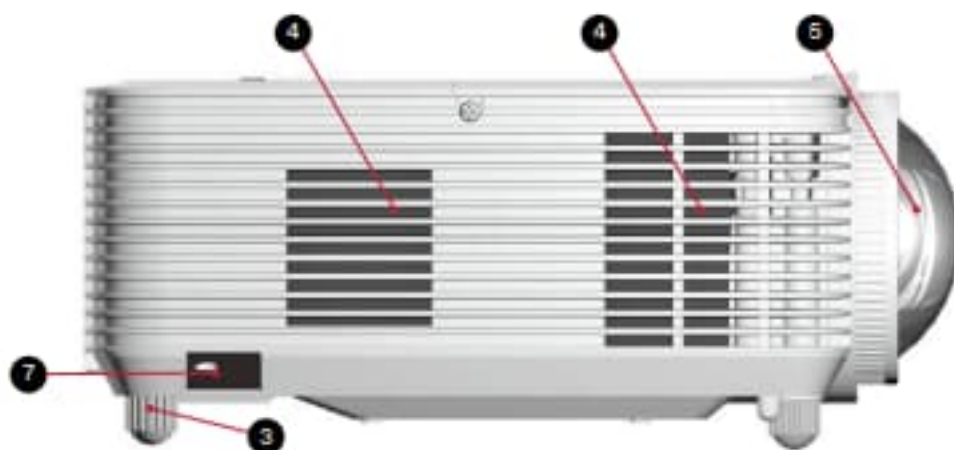

REGULATORY MODEL	SERIES NAME	LENS TYPE/ RESOLUTION	SVGA	XGA	WXGA	1080P
P123	INFOCUS LIGHTPRO VISTA II	SHORT THROW	-	IN00445T	IN00465T	IN00485T
P126	INFOCUS LIGHTPRO GENESIS IV	SHORT THROW	-	IN00245T	IN00265T	-

c)

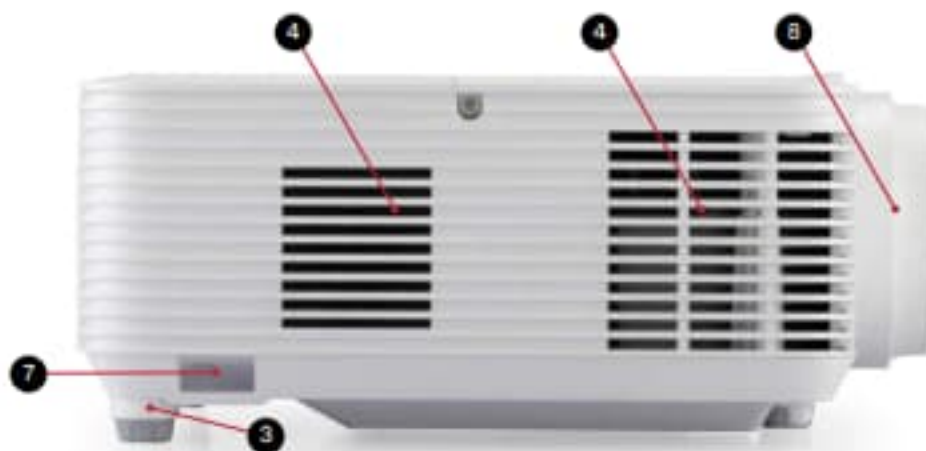

REGULATORY MODEL	SERIES NAME	LENS TYPE/ RESOLUTION	4K
P134	INFOCUS LIGHTPRO ORBITAL	STANDARD THROW	IN0061SL

2.3.4 TOP

a)

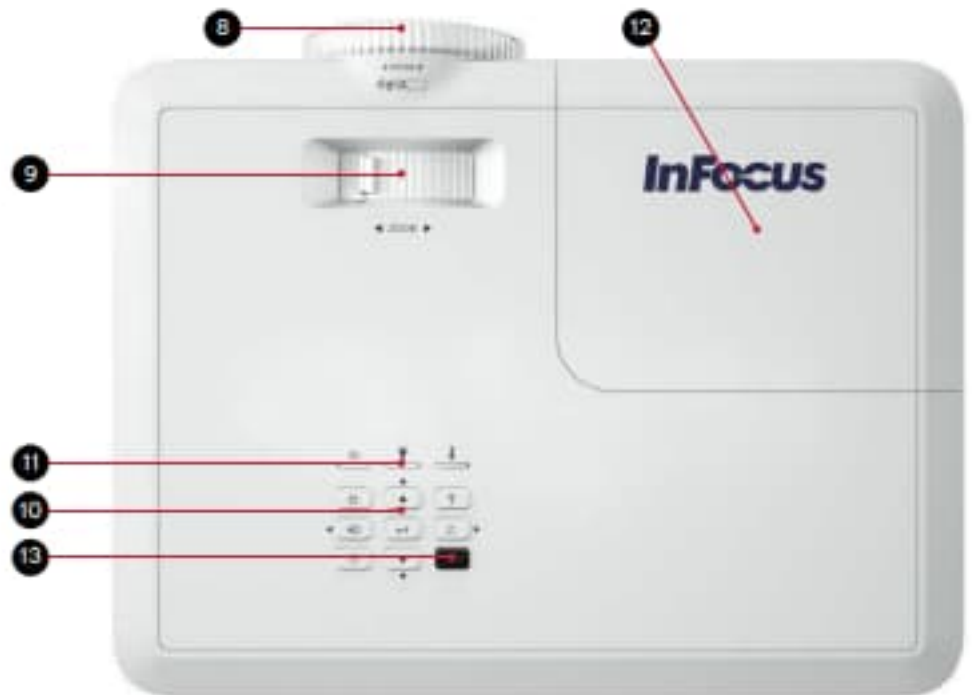

REGULATORY MODEL	SERIES NAME	LENS TYPE/ RESOLUTION	SVGA	XGA	WXGA	1080P
P122	INFOCUS LIGHTPRO VISTA II	STANDARD THROW	-	IN0044SL	IN0046SL	IN0048SL
P124	INFOCUS LIGHTPRO GENESIS III	STANDARD THROW	IN0002SL	IN0004SL	IN0006SL	-
P125	INFOCUS LIGHTPRO GENESIS IV	STANDARD THROW	IN0022SL	IN0024SL	IN0026SL	IN0028SL

b)

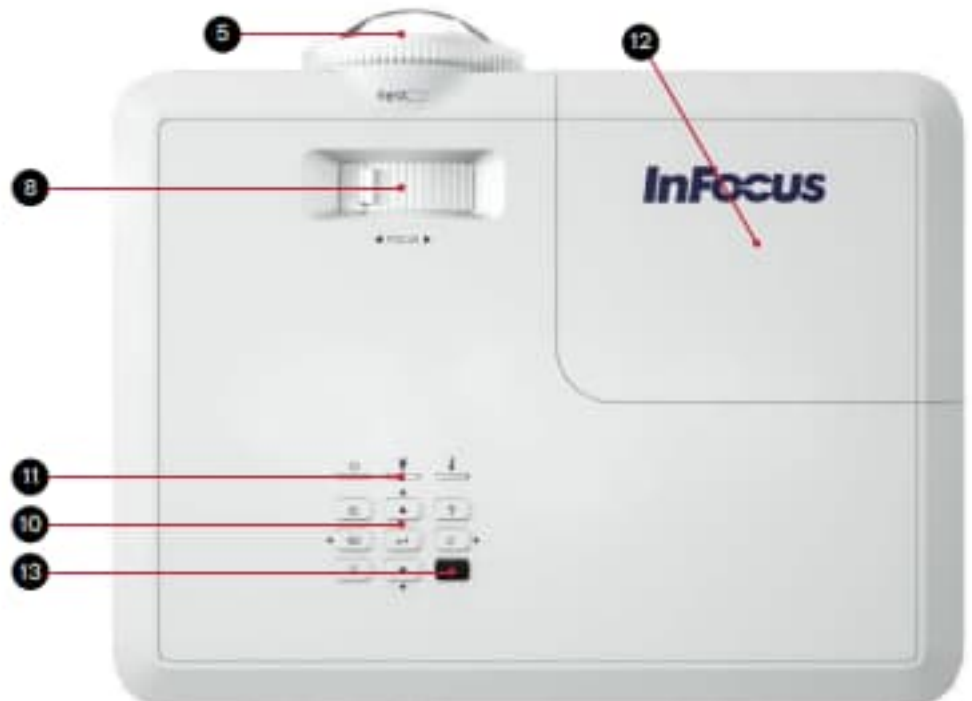

REGULATORY MODEL	SERIES NAME	LENS TYPE/ RESOLUTION	SVGA	XGA	WXGA	1080P
P123	INFOCUS LIGHTPRO VISTA II	SHORT THROW	-	IN0044ST	IN0046ST	IN0048ST
P126	INFOCUS LIGHTPRO GENESIS IV	SHORT THROW	-	IN0024ST	IN0026ST	-

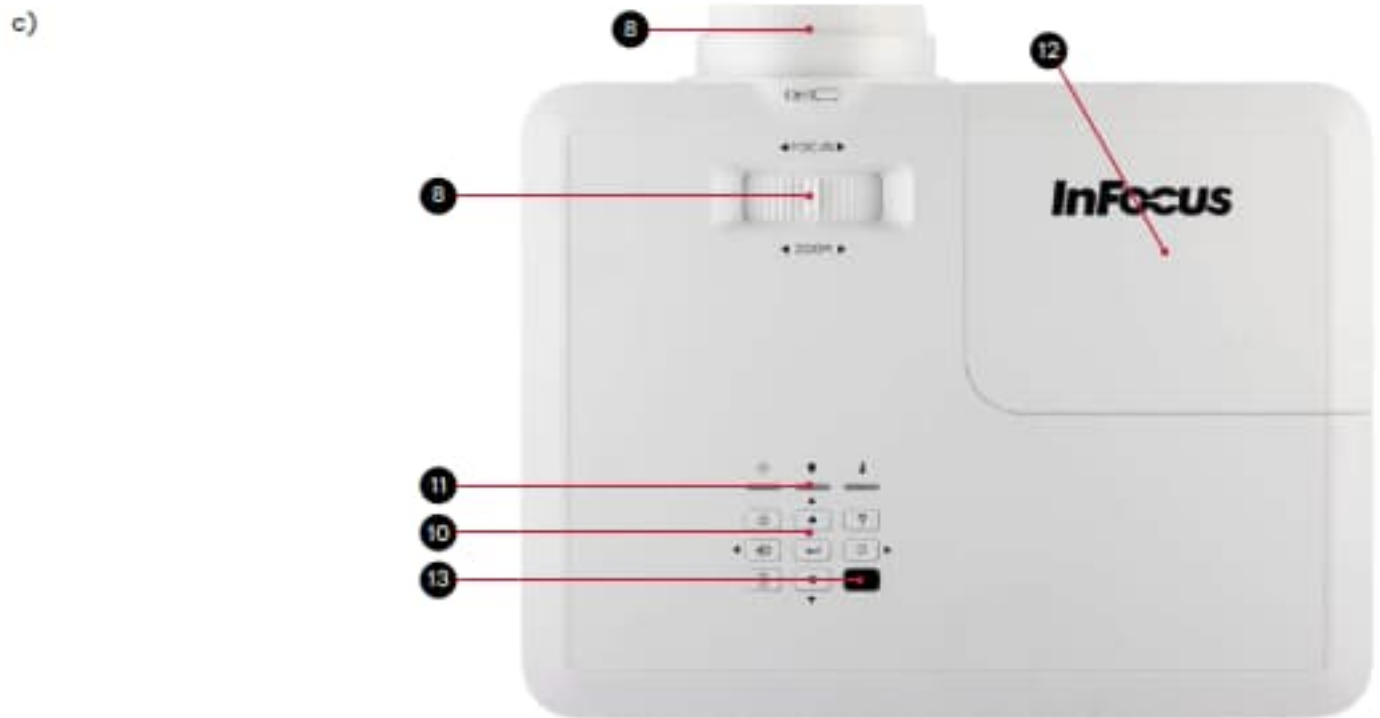

REGULATORY MODEL	SERIES NAME	LENS TYPE/ RESOLUTION	4K
P134	INFOCUS LIGHTPRO ORBITAL	STANDARD THROW	IN0061SL

2.3.5 BACK

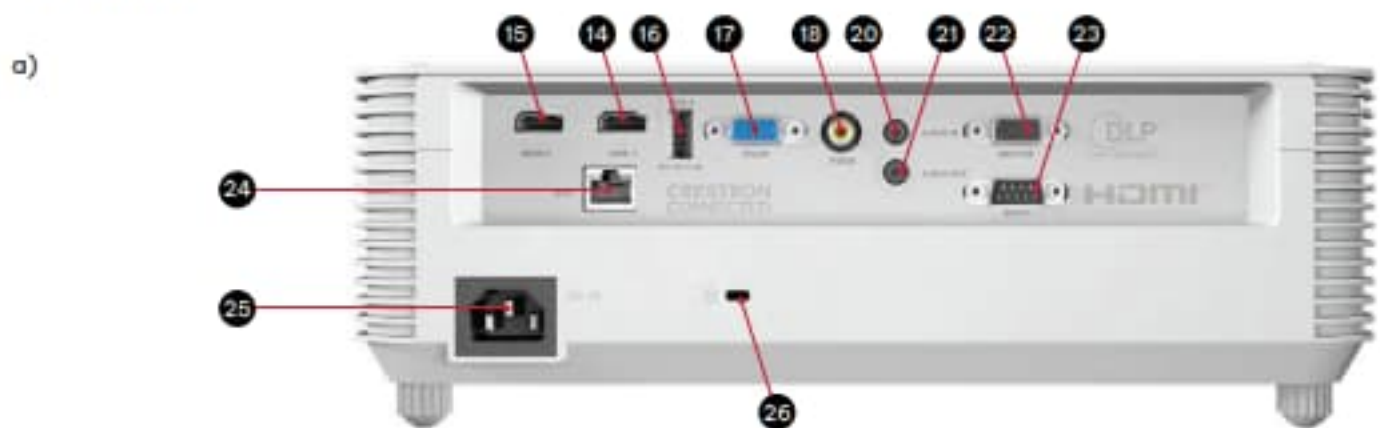

REGULATORY MODEL	SERIES NAME	LENS TYPE/ RESOLUTION	SVGA	XGA	WXGA	1080P
P122	INFOCUS LIGHTPRO VISTA II	STANDARD THROW	-	IN0044SL	IN0046SL	IN0048SL
P123	INFOCUS LIGHTPRO VISTA II	SHORT THROW	-	IN0024ST	IN0026ST	IN0028ST

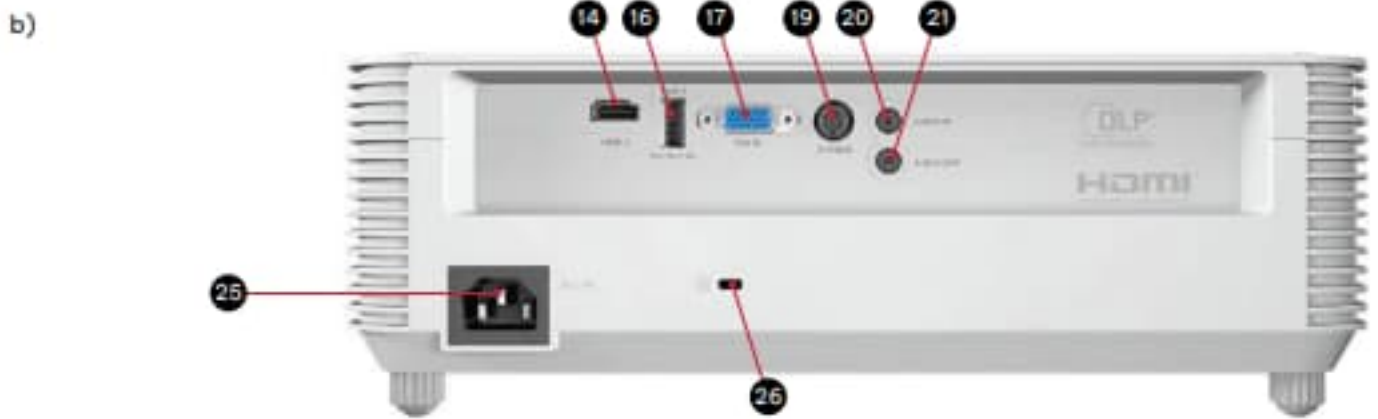

REGULATORY MODEL	SERIES NAME	LENS TYPE/ RESOLUTION	SVGA	XGA	WXGA	1080P
P124	INFOCUS LIGHTPRO GENESIS III	STANDARD THROW	IN0002SL	IN0004SL	IN0006SL	-

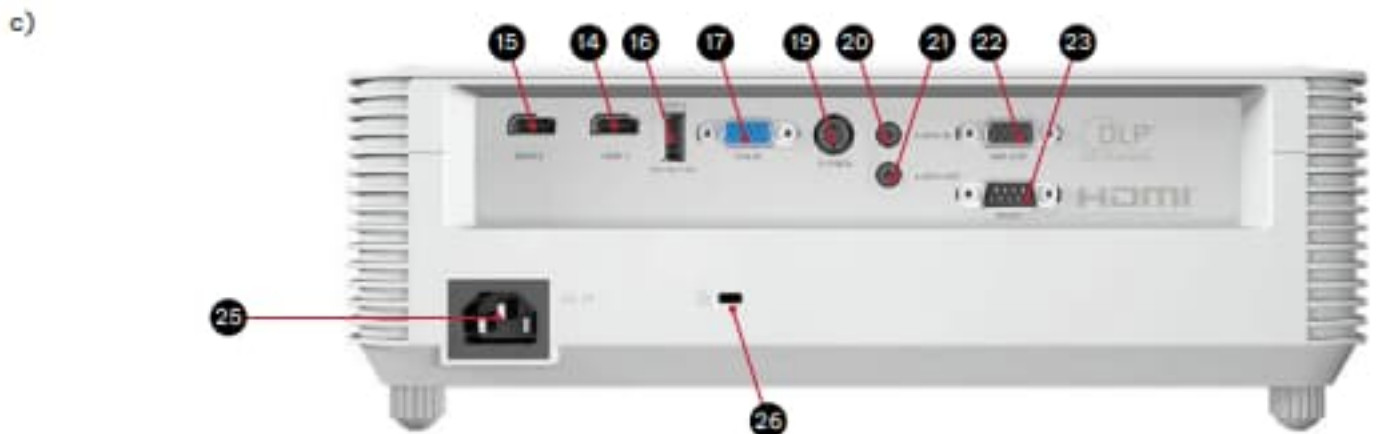

REGULATORY MODEL	SERIES NAME	LENS TYPE/ RESOLUTION	SVGA	XGA	WXGA	1080P
P125	INFOCUS LIGHTPRO GENESIS IV	STANDARD THROW	IN0022SL	IN0024SL	IN0026SL	IN0028SL
P126	INFOCUS LIGHTPRO GENESIS IV	SHORT THROW	-	IN0024ST	IN0026ST	-



REGULATORY MODEL	SERIES NAME	LENS TYPE/ RESOLUTION	4K
P134	INFOCUS LIGHTPRO ORBITAL	STANDARD THROW	IN0061SL

REFERENCE	DESCRIPTION	REFERENCE	DESCRIPTION
1	Standard throw zoom lens	16	USB A for service and wireless dangle power 5V/1.5A
2	Remote control IR receiver 1	17	VGA Input
3	Adjustable feet	18	Composite Input
4	Air exhaust grill	19	S-VIDEO Input
5	Short throw fixed lens	20	3.5mm Audio Input
6	Air Intake grill	21	3.5mm Audio Output
7	Cable and Lock slot	22	VGA Output
8	Focus adjustment ring	23	RS232 Control
9	Zoom adjustment ring	24	RJ45 Networking and Control
10	Keypad	25	Power Cord AC IN
11	LED function lights	26	Kensington Lock Slot
12	Lamp door	27	HDMI 1, 2.0
13	Remote control IR receiver 2	28	HDMI 2, 2.0
14	HDMI 1, 1.4 Input	29	S/PDIF Digital Audio Interface
15	HDMI 2, 1.4 Input		

3. SAFETY

Please refer to the projector's safety guide.



WARNING

Read and understand this guide and its safety instructions before using this product. Failure to do so can result in serious injury.

4.1 PACKAGING CONTENTS

The projector packaging will contain:

- Projector
- Power cable
- VGA cable or HDMI cable
- Remote control (batteries not included)
- Simplified users guide

4.2 INSTALLATION INSTRUCTIONS

Your projector is designed to be installed in one of four possible positions. Your room layout or personal preference will dictate which installation location you select. Take into consideration the size and position of your screen, the location of a suitable power outlet, as well as the location and distance between the projector and the rest of your equipment.

1. Table mounted front projection
2. Table mounted rear projection
3. Ceiling mounted front projection
4. Ceiling mounted rear projection

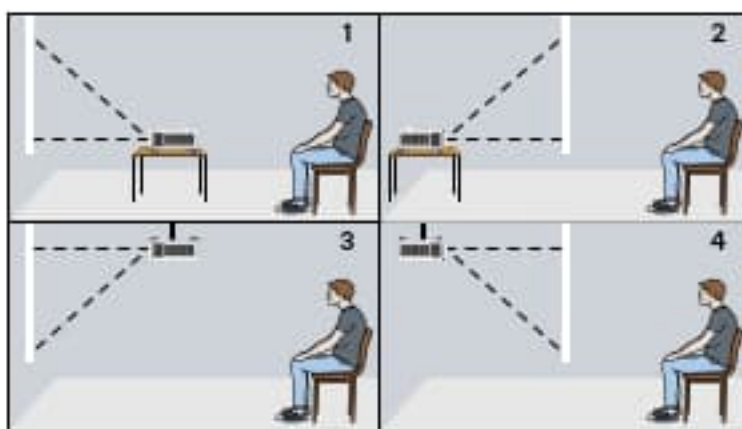

4.3 PLACEMENT AND DISTANCE FROM THE SCREEN

The projected image size will increase based on the projector's distance from the screen or projection surface. You can use the following tables to determine the best location for the projector and screen.

4.3.1 PROJECTION DISTANCE AND SCREEN SIZE

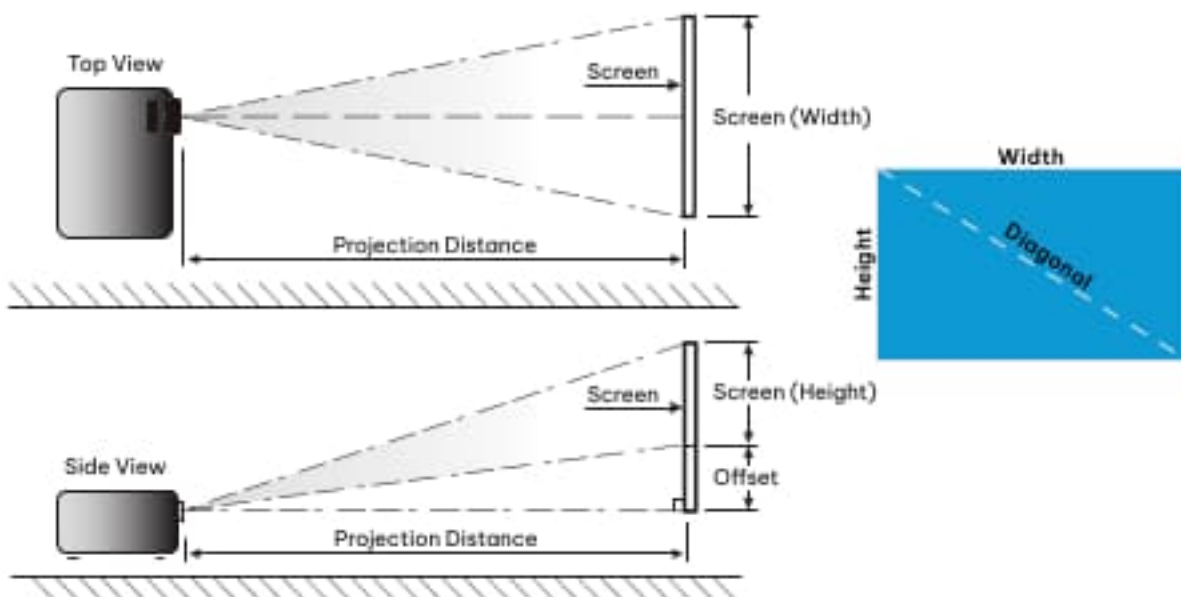

IN0044SL_RT_XGA 1.3• ZOOM

Diagonal Screen (inch)	Screen size				Projection distance				Offset	
	(m)		(inch)		(m)		(inch)		(cm)	(inch)
	Width	Height	Width	Height	Wide	Tele	Wide	Tele		
30	0.61	0.46	24.02	18.11	0.9	1.2	35.43	47.24	7	2.8
40	0.81	0.61	31.89	24.02	1.2	1.6	47.24	62.99	9	3.5
50	1.02	0.76	40.16	29.92	1.5	2.0	59.06	78.74	12	4.7
60	1.22	0.91	48.03	35.83	1.8	2.4	70.87	94.49	14	5.5
70	1.42	1.07	55.91	42.13	2.1	2.7	82.68	106.30	16	6.3
80	1.63	1.22	64.17	48.03	2.4	3.1	94.49	122.05	18	7.1
90	1.83	1.37	72.05	53.94	2.7	3.5	106.30	137.80	21	8.3
100	2.03	1.52	79.92	59.84	3.0	3.9	118.11	153.54	23	9.1
120	2.44	1.83	96.06	72.05	3.6	4.7	141.73	185.04	27	10.6
150	3.05	2.29	120.08	90.16	4.5	5.9	177.17	232.28	34	13.4
200	4.06	3.05	159.84	120.08	6.0	7.8	236.22	307.09	46	18.1
250	5.08	3.81	200.00	150.00	7.5	9.8	295.28	385.83	57	22.4
300	6.1	4.57	240.16	179.92	9.0	–	354.33	–	69	27.2

IN0046SL_RT_WXGA 1.3• ZOOM

Diagonal Screen (inch)	Screen size				Projection distance				Offset	
	(m)		(inch)		(m)		(inch)		(cm)	(inch)
	Width	Height	Width	Height	Wide	Tele	Wide	Tele		
30	0.65	0.4	25.59	15.75	0.8	1.0	31.5	39.4	5	1.97
40	0.86	0.54	33.86	21.26	1.0	1.3	39.4	51.2	7	2.76
50	1.08	0.67	42.52	26.38	1.3	1.7	51.2	66.9	9	3.54
60	1.29	0.81	50.79	31.89	1.5	2.0	59.1	78.7	10	3.94
70	1.51	0.94	59.45	37.01	1.8	2.3	70.9	90.6	12	4.72
80	1.72	1.08	67.72	42.52	2.0	2.7	78.7	106.3	13	5.12
90	1.94	1.21	76.38	47.64	2.3	3.0	90.6	118.1	15	5.91
100	2.15	1.35	84.65	53.15	2.6	3.3	102.4	129.9	16	6.30
120	2.58	1.62	101.57	63.78	3.1	4.0	122.0	157.5	20	7.87
150	3.23	2.02	127.17	79.53	3.8	5.0	149.6	196.9	25	9.84
200	4.31	2.69	169.69	105.91	5.1	6.7	200.8	263.8	34	13.39
250	5.38	3.37	211.81	132.68	6.4	8.3	252.0	326.8	41	16.14
300	6.46	4.04	254.33	159.06	7.7	–	303.1	–	52	20.47

IN0048SL_RT_1080p 1.3• ZOOM

Diagonal Screen (inch)	Screen size				Projection distance				Offset	
	(m)		(inch)		(m)		(inch)		(cm)	(inch)
	Width	Height	Width	Height	Wide	Tele	Wide	Tele		
30	0.66	0.37	26.98	14.57	0.8	1	31.50	39.37	6	2.36
40	0.89	0.50	35.04	19.69	1	1.3	39.37	51.18	8	3.15
50	1.11	0.62	43.70	24.41	1.3	1.6	51.18	62.99	10	3.94
60	1.33	0.75	52.36	29.53	1.5	2	59.06	78.74	12	4.72
70	1.55	0.87	61.02	34.25	1.8	2.3	70.87	90.55	14	5.51
80	1.77	1.00	69.69	39.37	2	2.6	78.74	102.36	16	6.30
90	1.99	1.12	78.35	44.09	2.3	2.9	90.55	114.17	18	7.09
100	2.21	1.25	87.01	49.21	2.5	3.3	98.43	129.92	19	7.48
120	2.66	1.49	104.72	58.66	3	3.9	118.11	153.54	24	9.45
150	3.32	1.87	130.71	73.62	3.8	4.9	149.61	192.91	30	11.81
200	4.43	2.49	174.41	98.03	5	6.5	196.85	255.91	40	15.75
250	5.53	3.11	217.72	122.44	6.3	8.1	248.03	318.90	50	19.69
300	6.64	3.74	261.42	147.24	7.5	–	295.28	–	59	23.23

IN00445T_ST_XGA 1:1• ZOOM

Diagonal Screen (inch)	Screen size				Projection distance		Offset	
	(m)		(inch)		(m)	(inch)	(cm)	(inch)
	Width	Height	Width	Height	Wide	Wide		
40	0.81	0.61	32.01	24.02	0.5	19.69	9	3.54
50	1.02	0.76	40.00	30.00	0.63	24.80	11.8	4.65
60	1.22	0.91	47.99	35.98	0.75	29.53	13.6	5.35
70	1.42	1.07	55.98	42.01	0.88	34.65	16.3	6.42
80	1.63	1.22	64.02	47.99	1	39.37	18.1	7.13
90	1.83	1.37	72.01	54.02	1.13	44.49	20.8	8.19
100	2.03	1.52	80.00	60.00	1.25	49.21	22.6	8.90
120	2.44	1.83	95.98	72.01	1.5	59.06	27.1	10.67
150	3.05	2.29	120.00	90.00	1.88	74.02	34.4	13.54
180	3.66	2.74	144.02	107.99	2.26	88.98	40.7	16.02
250	5.08	3.81	200.00	150.00	3.13	123.23	57	22.44
303	6.16	4.62	242.40	181.81	3.8	149.61	69.2	27.24

IN0046ST_ST_WXGA 1:1• ZOOM

Diagonal Screen (inch)	Screen size				Projection distance		Offset	
	(m)		(inch)		(m)	(inch)	(cm)	(inch)
	Width	Height	Width	Height	Wide	Wide		
40	0.86	0.54	33.92	21.20	0.45	17.72	7.15	2.81
50	1.08	0.67	42.40	26.50	0.56	22.05	8.69	3.42
60	1.29	0.81	50.88	31.80	0.67	26.38	10.23	4.03
70	1.51	0.94	59.36	37.10	0.79	31.10	11.77	4.63
80	1.72	1.08	67.84	42.40	0.9	35.43	13.3	5.24
90	1.94	1.21	76.32	47.70	1.01	39.76	14.84	5.84
100	2.15	1.35	84.80	53.00	1.12	44.09	16.38	6.45
120	2.58	1.62	101.76	63.60	1.35	53.15	20.46	8.06
150	3.23	2.02	127.20	79.50	1.68	66.14	25.07	9.87
180	3.88	2.42	152.64	95.40	2.02	79.53	29.68	11.69
250	5.38	3.37	212.00	132.50	2.81	110.63	41.45	16.32
302.9	6.52	4.08	256.86	160.54	3.4	133.86	50.24	19.78

IN0048ST_ST_1080p1:1• ZOOM

Diagonal Screen (inch)	Screen size				Projection distance		Offset	
	(m)		(inch)		(m)	(inch)	(cm)	(inch)
	Width	Height	Width	Height	Wide	Wide		
40	0.89	0.50	34.86	19.61	0.44	17.32	8.19	3.22
50	1.11	0.62	43.58	24.51	0.55	21.65	9.74	3.83
60	1.33	0.75	52.30	29.42	0.66	25.98	12.28	4.83
70	1.55	0.87	61.01	34.32	0.77	30.31	13.83	5.44
80	1.77	1.00	69.72	39.22	0.88	34.65	16.38	6.45
90	1.99	1.12	78.44	44.12	0.99	38.98	17.93	7.06
100	2.21	1.25	87.16	49.03	1.10	43.31	19.47	7.67
120	2.66	1.49	104.59	58.83	1.32	51.97	23.57	9.28
150	3.32	1.87	130.74	73.54	1.65	64.96	30.21	11.89
180	3.98	2.24	156.88	88.25	1.98	77.95	36.85	14.11
250	5.53	3.11	217.89	122.57	2.75	108.27	49.68	19.56
302.9	6.71	3.77	264.00	148.50	3.33	131.10	60.81	23.94

IN0002SL, IN0004SL, IN0022SL, IN0024SL_RT_SVGA & XGA_1.1• ZOOM

Diagonal Screen (inch)	Screen size				Projection distance				Offset	
	(m)		(inch)		(m)		(inch)		(cm)	(inch)
	Width	Height	Width	Height	Wide	Tele	Wide	Tele		
30	0.61	0.46	24.00	18.00	1.18	1.32	46.56	51.84	6.86	2.70
40	0.81	0.61	32.00	24.00	1.58	1.76	62.08	69.12	9.14	3.60
50	1.02	0.76	40.00	30.00	1.97	2.19	77.60	86.40	11.43	4.50
60	1.22	0.91	48.00	36.00	2.37	2.63	93.12	103.68	13.72	5.40
70	1.42	1.07	56.00	42.00	2.76	3.07	108.64	120.96	16.00	6.30
80	1.63	1.22	64.00	48.00	3.15	3.51	124.16	138.24	18.29	7.20
90	1.83	1.37	72.00	54.00	3.55	3.95	139.68	155.52	20.57	8.10
100	2.03	1.52	80.00	60.00	3.94	4.39	155.20	172.80	22.86	9.00
120	2.44	1.83	96.00	72.00	4.73	5.27	186.24	207.36	27.43	10.80
150	3.05	2.29	120.00	90.00	5.91	6.58	232.80	259.20	34.29	13.50
200	4.06	3.05	160.00	120.00	7.88	8.78	310.40	345.60	45.72	18.00
250	5.08	3.81	200.00	150.00	9.86	10.97	388.00	432.00	57.15	22.50
300	6.10	4.57	240.00	180.00	11.83	13.17	465.60	518.40	68.58	27.00

IN0006SL, IN0026SL_RT_WXGA_1.1• ZOOM

Diagonal Screen (inch)	Screen size				Projection distance				Offset	
	(m)		(inch)		(m)		(inch)		(cm)	(inch)
	Width	Height	Width	Height	Wide	Tele	Wide	Tele		
30	0.65	0.40	26.44	15.90	1.00	1.11	39.18	43.76	5.01	1.97
40	0.86	0.54	33.92	21.20	1.33	1.48	52.24	58.34	6.68	2.63
50	1.08	0.67	42.40	26.50	1.66	1.85	65.30	72.93	8.35	3.29
60	1.29	0.81	50.88	31.80	1.99	2.22	78.36	87.51	10.02	3.94
70	1.51	0.94	59.36	37.10	2.32	2.59	91.41	102.10	11.68	4.60
80	1.72	1.08	67.84	42.40	2.65	2.96	104.47	116.68	13.35	5.26
90	1.94	1.21	76.32	47.70	2.99	3.33	117.53	131.27	15.02	5.91
100	2.15	1.35	84.80	53.00	3.32	3.70	130.59	145.86	16.69	6.57
120	2.58	1.62	101.76	63.60	3.98	4.45	156.71	175.03	20.03	7.89
150	3.23	2.02	127.20	79.50	4.98	5.56	195.89	218.78	25.04	9.86
200	4.31	2.69	169.60	106.00	6.63	7.41	261.18	291.71	33.39	13.14
250	5.38	3.37	212.00	132.50	8.29	9.26	326.48	364.64	41.73	16.43
300	6.46	4.04	254.40	159.00	9.95	11.11	391.78	437.57	50.08	19.72

IN0028SL_RT_1080p_1.1• ZOOM

Diagonal Screen (inch)	Screen size				Projection distance				Offset	
	(m)		(inch)		(m)		(inch)		(cm)	(inch)
	Width	Height	Width	Height	Wide	Tele	Wide	Tele		
30	0.66	0.37	26.15	14.71	0.98	1.08	38.44	42.36	5.98	2.35
40	0.89	0.50	34.86	19.61	1.30	1.43	51.25	56.48	7.97	3.14
50	1.11	0.62	43.58	24.51	1.63	1.79	64.06	70.60	9.96	3.92
60	1.33	0.75	52.29	29.42	1.95	2.15	76.87	84.72	11.95	4.71
70	1.55	0.87	61.01	34.32	2.28	2.51	89.69	98.84	13.95	5.49
80	1.77	1.00	69.73	39.22	2.60	2.87	102.50	112.96	15.94	6.28
90	1.99	1.12	78.44	44.12	2.93	3.23	115.31	127.08	17.93	7.06
100	2.21	1.25	87.16	49.03	3.25	3.59	128.12	141.20	19.92	7.84
120	2.66	1.49	104.59	58.83	3.91	4.30	153.75	169.43	23.91	9.41
150	3.32	1.87	130.74	73.54	4.88	5.38	192.18	211.79	29.89	11.77
200	4.43	2.49	174.32	98.05	6.51	7.17	256.24	282.39	39.85	15.69
250	5.53	3.11	217.89	122.57	8.14	8.97	320.30	352.99	49.81	19.61
300	6.64	3.74	261.47	147.08	9.76	10.76	384.36	423.59	59.77	23.53

IN0024ST_ST_XGA_Fixed Lens

Diagonal Screen (inch)	Screen size				Projection distance		Offset	
	(m)		(inch)		(m)	(inch)	(cm)	(inch)
	Width	Height	Width	Height	Wide	Wide		
30	0.61	0.46	24.00	18.00	0.32	12.48	5.67	2.23
40	0.81	0.61	32.00	24.00	0.42	16.64	7.56	2.98
50	1.02	0.76	40.00	30.00	0.53	20.80	9.45	3.72
60	1.22	0.91	48.00	36.00	0.63	24.96	11.34	4.46
70	1.42	1.07	56.00	42.00	0.74	29.12	13.23	5.21
80	1.63	1.22	64.00	48.00	0.85	33.28	15.12	5.95
90	1.83	1.37	72.00	54.00	0.95	37.44	17.01	6.70
100	2.03	1.52	80.00	60.00	1.06	41.60	18.90	7.44
120	2.44	1.83	96.00	72.00	1.27	49.92	22.68	8.93
150	3.05	2.29	120.00	90.00	1.58	62.40	28.35	11.16
200	4.06	3.05	160.00	120.00	2.11	83.20	37.80	14.88
250	5.08	3.81	200.00	150.00	2.64	104.00	47.24	18.60
300	6.10	4.57	240.00	180.00	3.17	124.80	56.69	22.32

IN0026ST_ST_WXGA_Fixed Lens

Diagonal Screen (inch)	Screen size				Projection distance		Offset	
	(m)		(inch)		(m)	(inch)	(cm)	(inch)
	Width	Height	Width	Height	Wide	Wide		
30	0.65	0.40	26.44	15.90	0.34	13.23	5.01	1.97
40	0.86	0.54	33.92	21.20	0.45	17.64	6.68	2.63
50	1.08	0.67	42.40	26.50	0.56	22.05	8.35	3.29
60	1.29	0.81	50.88	31.80	0.67	26.46	10.02	3.94
70	1.51	0.94	59.36	37.10	0.78	30.87	11.68	4.60
80	1.72	1.08	67.84	42.40	0.90	35.28	13.35	5.26
90	1.94	1.21	76.32	47.70	1.01	39.69	15.02	5.91
100	2.15	1.35	84.80	53.00	1.12	44.10	16.69	6.57
120	2.58	1.62	101.76	63.60	1.34	52.92	20.03	7.89
150	3.23	2.02	127.20	79.50	1.68	66.14	25.04	9.86
200	4.31	2.69	169.60	106.00	2.24	88.19	33.39	13.14
250	5.38	3.37	212.00	132.50	2.80	110.24	41.73	16.43
300	6.46	4.04	254.40	159.00	3.36	132.29	50.08	19.72

IN0061SL_RT_4K_1.3x ZOOM

Diagonal Screen (inch)	Screen Size W x H				Projection distance (D)				Offset (HD)	
	(m)		(inch)		(m)		(feet)		(m)	(feet)
	Width	Height	Width	Height	Wide	Tele	Wide	Tele		
30	0.66	0.37	26.1	14.7	–	1.06	–	3.46	0.02	0.07
40	0.89	0.50	34.9	19.6	1.07	1.41	3.51	4.62	0.03	0.09
60	1.33	0.75	52.3	29.4	1.61	2.11	5.27	6.93	0.04	0.13
70	1.55	0.87	61.0	34.3	1.88	2.46	6.15	8.08	0.05	0.16
80	1.77	1.00	69.7	39.2	2.14	2.82	7.03	9.24	0.05	0.18
90	1.99	1.12	78.4	44.1	2.41	3.17	7.91	10.39	0.06	0.20
100	2.21	1.25	87.2	49.0	2.68	3.52	8.78	11.55	0.07	0.22
120	2.66	1.49	104.6	58.8	3.21	4.22	10.54	13.86	0.08	0.27
150	3.32	1.87	130.7	73.5	4.02	5.28	13.18	17.32	0.10	0.34
180	3.98	2.24	156.9	88.2	4.82	6.34	15.81	20.79	0.12	0.40
200	4.43	2.49	174.3	98.1	5.36	7.04	17.57	23.10	0.14	0.45
250	5.53	3.11	217.9	122.6	6.70	8.80	21.96	28.87	0.17	0.56
300.6	6.65	3.74	262.0	147.4	8.05	–	26.40	–	0.21	0.68

4.4 CLEARANCE

Allow at least 30cm clearance around the intake and exhaust vent and ensure that the intake vents do not recycle hot air from the exhaust vent.

REFERENCE	DESCRIPTION
1	Air intake vent
2	Air outtake vent

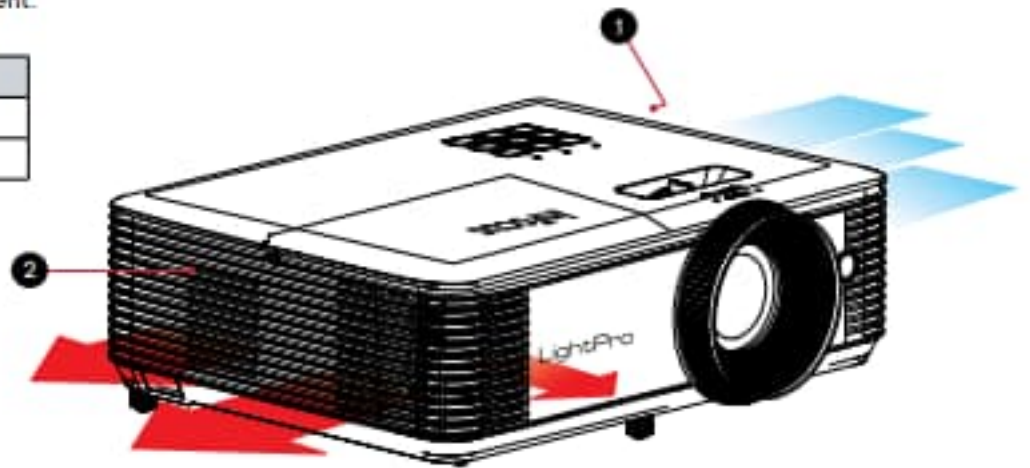

When operating the projector in an enclosed space:

- The surrounding air temperature within the enclosure should not exceed operation temperature while the projector is running
- The air intake and exhaust vents should be unobstructed
- The enclosure should pass a certified thermal evaluation to ensure that the projector does not recycle exhaust air

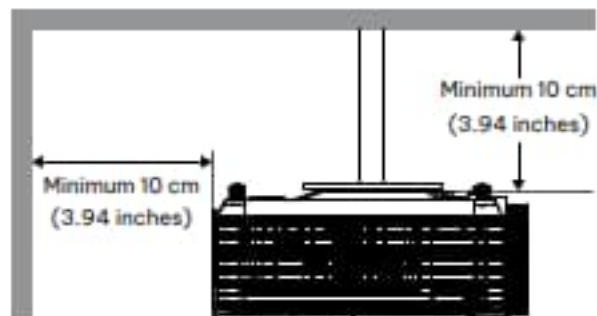

4.5 CEILING MOUNT

- Screw type: M4*10
- Minimum screw length: 10mm

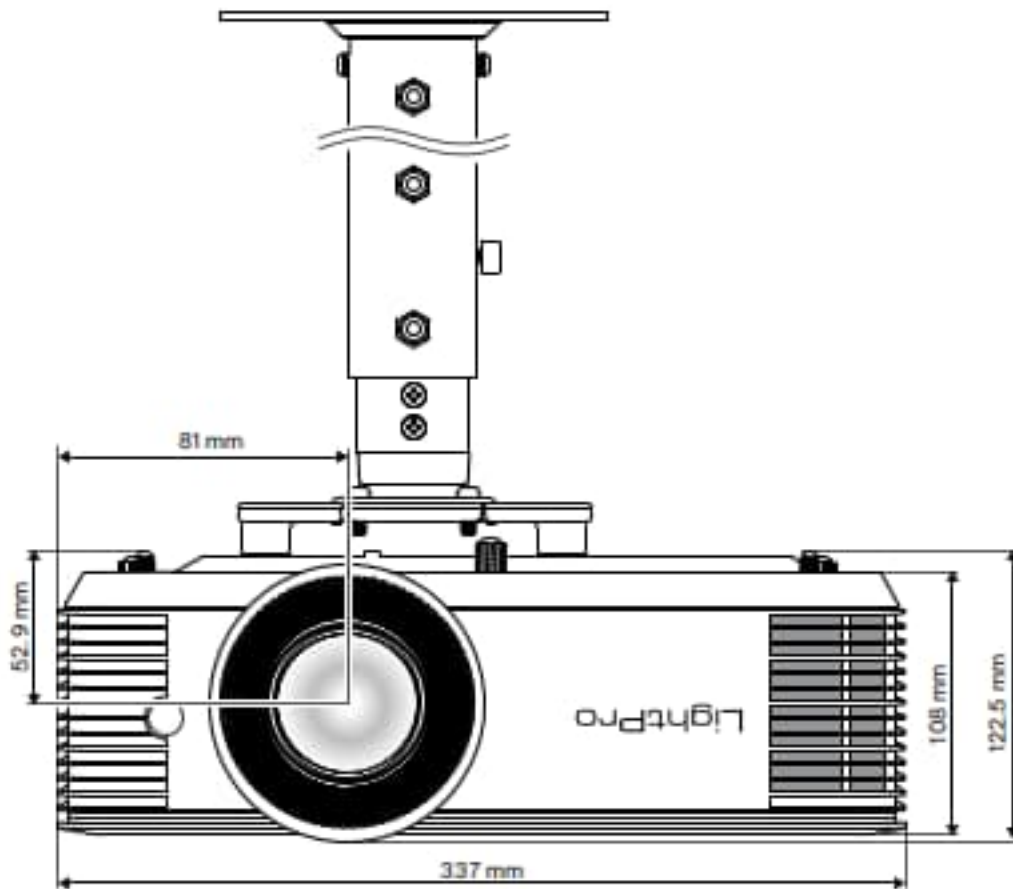

INFORMATION

Please note that damage resulting from incorrect installation will void the warranty. If you buy a ceiling mount from another company, please be sure to use the correct screw size. Screw size will vary depending on the thickness of the mounting plate.

4.6 MOUNTING HOLE DIAGRAM

When using a ceiling mount, please be sure to use the correct screw size. Screw size will vary depending on the thickness of the mounting plate.

Be sure to keep at least 10 cm gap between the ceiling and the bottom of the projector.

Avoid installing the projector near a heat source.

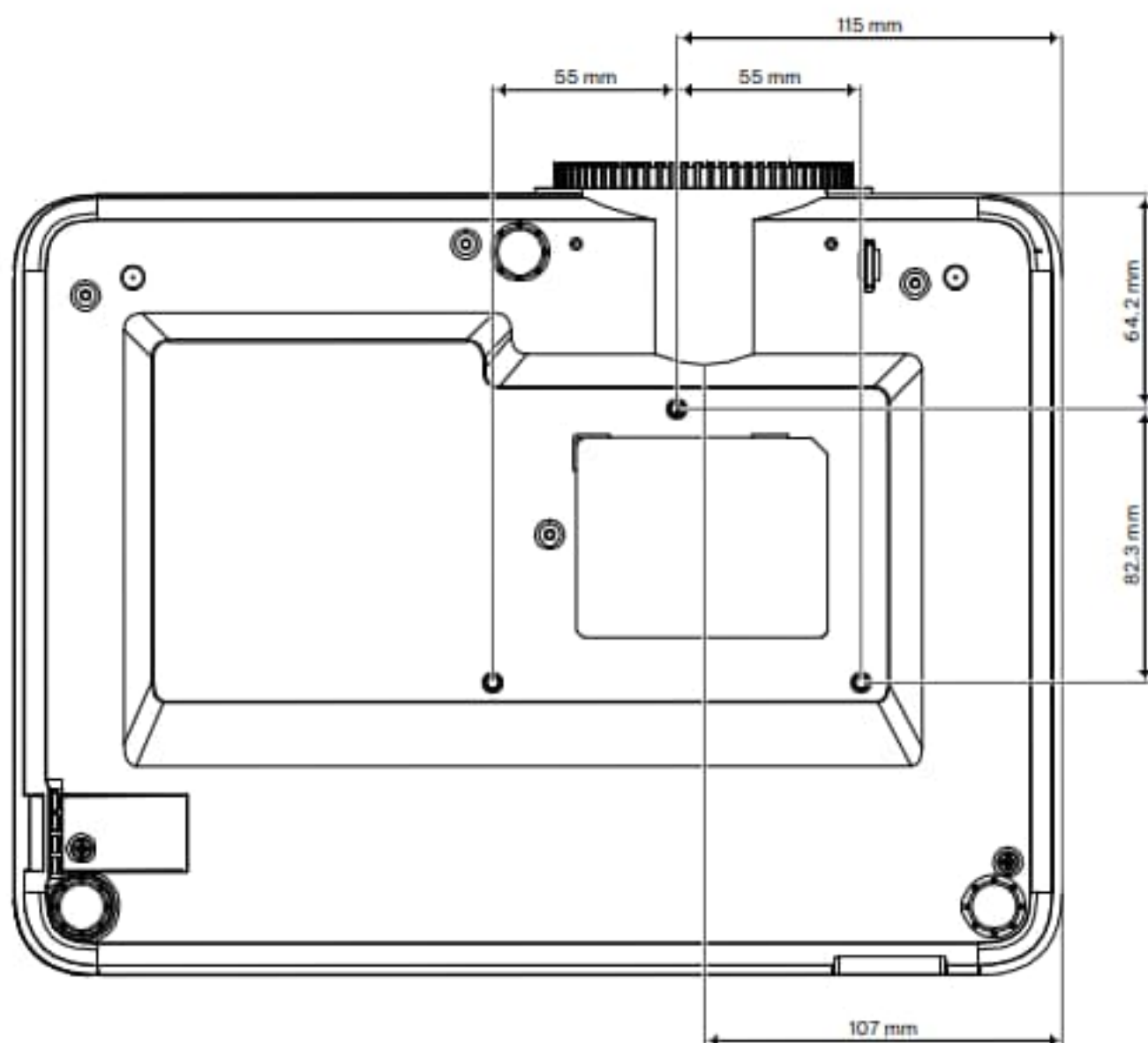

5. ADJUSTING

5.1 ADJUSTING THE IMAGE HEIGHT AND TILT

The projector's height and tilt can be adjusted with the tilt adjustment feet and ring. Locate the adjustable foot you wish to adjust on the underside of the projector. Rotate the foot clockwise or counterclockwise to raise or lower the projector.

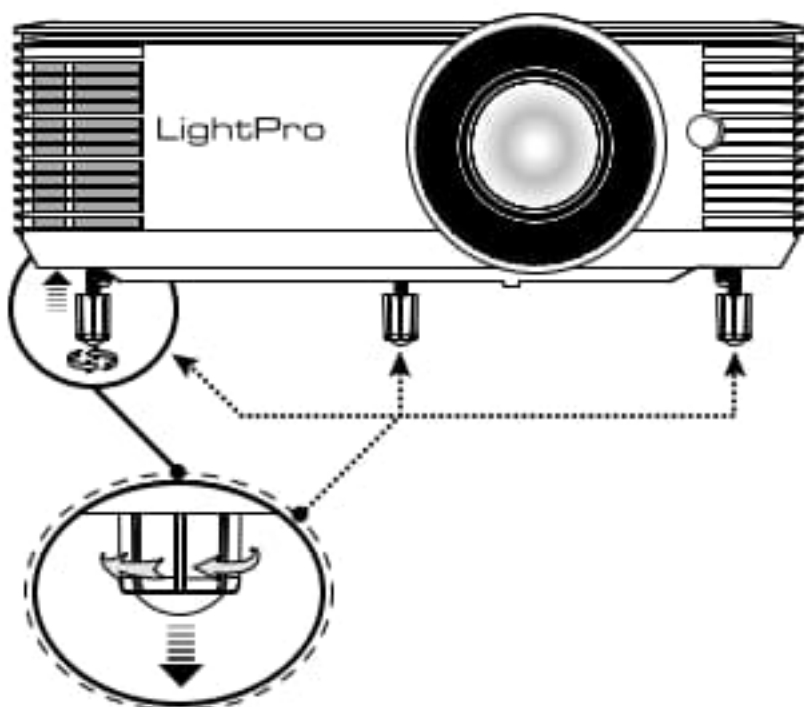

5.2 ADJUSTING THE ZOOM, LENS SHIFT AND FOCUS

To adjust the image size, turn the zoom ring clockwise or counterclockwise to increase or decrease the projected image size.

To adjust the image position, turn the lens shift dial clockwise or counterclockwise to adjust the position of the projected image vertically. (Not available on all models.)

To adjust the focus, turn the focus ring clockwise or counterclockwise until the image is sharp and legible.

5.3 ADJUSTING THE VERTICAL AND HORIZONTAL KEYSTONE

If one side of the image is shorter than the other, for example the top is shorter than the bottom, you can either reposition the projector or use keystone correction.

To adjust the top or bottom of the picture (the pitch), angle the projector lower or higher. If that is not possible, adjust the vertical keystone:

Press the Menu button on the projector keypad or the Menu button on the remote control to open the OSD menu.

Select Image > V Keystone

Adjust the settings by using the arrow keys

Press the Return symbol or Enter button to select a setting.

Press the Menu symbol or Menu button to close the OSD menu. The menu will close and the projector will automatically save the new settings.

To adjust the left or right side of the picture (the yaw), turn the projector slightly left or right. If that is not possible, adjust the horizontal keystone:

Press the Menu button on the projector keypad or the Menu button on the remote control to open the OSD menu.

Select Image > H Keystone

Note horizontal keystone correction is not available on all models

Adjust the settings by using the Arrow keys.

Press the Return symbol or Enter button to select a setting.

Press the Menu button to close the OSD menu. The menu will close and the projector will automatically save the new settings.



INFORMATION

Ensure that the projection screen or projection surface is within the required distance from the projector. Refer to "4.3 Placement distance from screen" for more information.

6.1 CONNECTION DIAGRAM

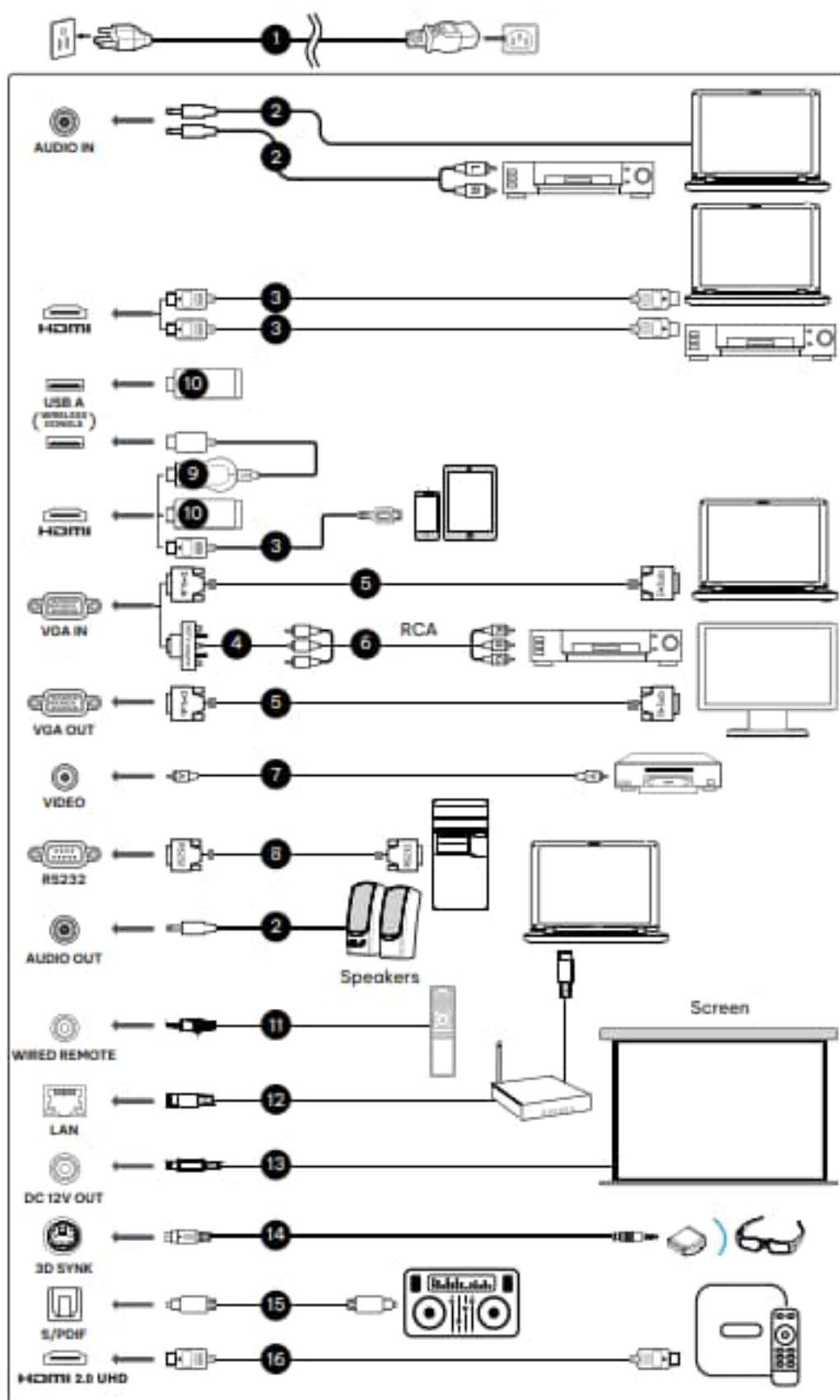

REFERENCE	DESCRIPTION
1	Power cord
2	Audio cable
3	HDMI (MHL) cable
4	VGA to component/HDTV adapter
5	VGA cable
6	3 RCA component cable
7	Composite video cable
8	RS232 cable

REFERENCE	DESCRIPTION
9	WirelessHD dongle
10	Wireless dongle
11	Wired remote control
12	LAN cable
13	12V DC cable
14	3D SYNC cable
15	S/PDIF
16	HDMI 2.0 UHD



INFORMATION

Not all inputs are available on all models.

7. USING

7.1 LEDS

REFERENCE	DESCRIPTION
1	Power
2	Lamp
3	Temperature



7.2 KEYPAD

REFERENCE	DESCRIPTION
1	Up / Keystone correction +
2	Information
3	Right / Re-sync
4	Enter
5	PowerDown / Keystone correction -
6	Menu
7	Directional arrows
8	Left / Source
9	Power

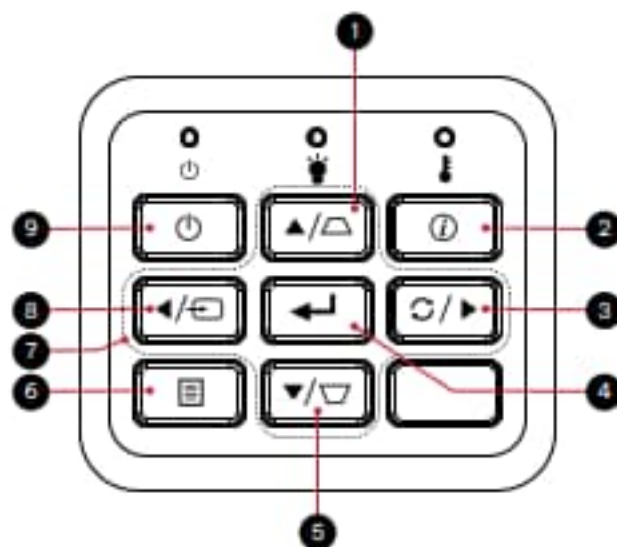

7.3 REMOTE CONTROL

REFERENCE	DESCRIPTION
1	IR LED
2	Power
3	Source
4	Enter
5	ECO
6	Volume
7	Aspect
8	HDMI – Press once for HDMI 1 and twice for HDMI 2
9	Zoom
10	Mute
11	Freeze
12	Picture
13	Mouse
14	Page
15	VGA
16	Video
17	Keystone correction
18	Menu
19	Directional keys
20	Re-sync
21	AV Mute

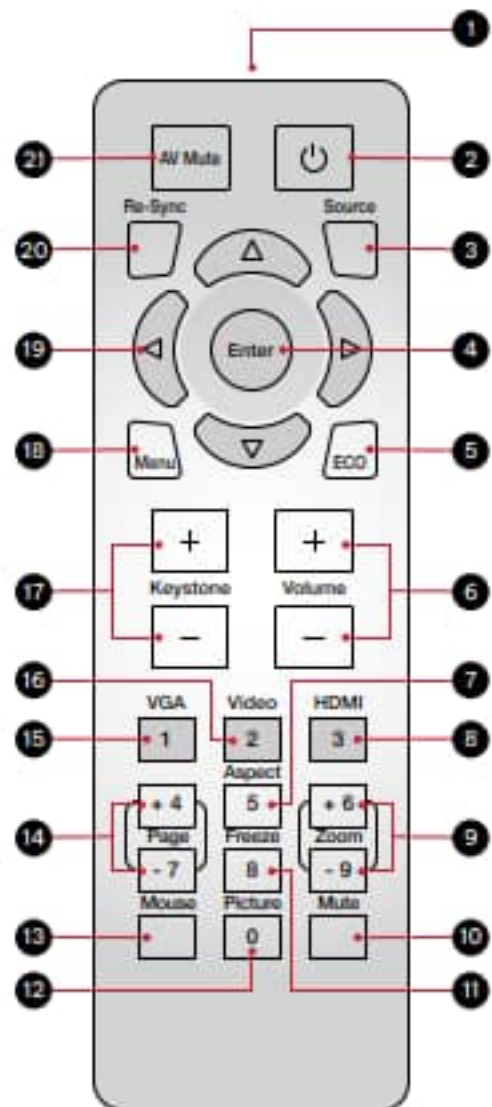

INFORMATION

Some keys may have no function for models that do not support the key's feature.

7.3.1 INSTALLING BATTERIES IN THE REMOTE CONTROL

The remote requires two AAA batteries (not included).

1. Remove the battery cover on the back of the remote control.

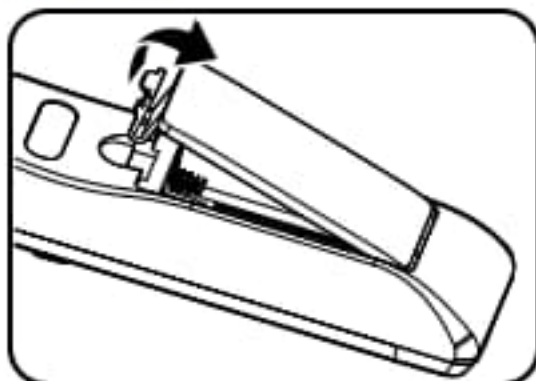

2. Insert AAA batteries in the battery compartment. Ensure each battery's polarity \pm is aligned correctly.

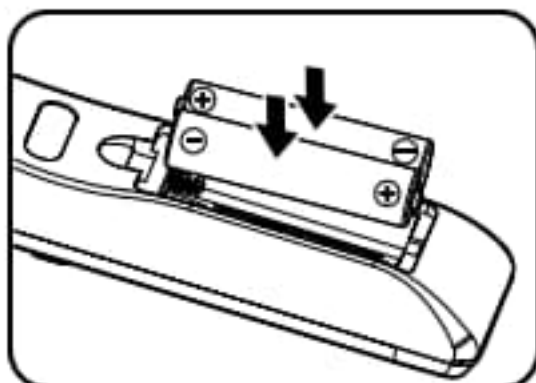

3. Replace back cover on the remote control and press down until it clicks in to place.

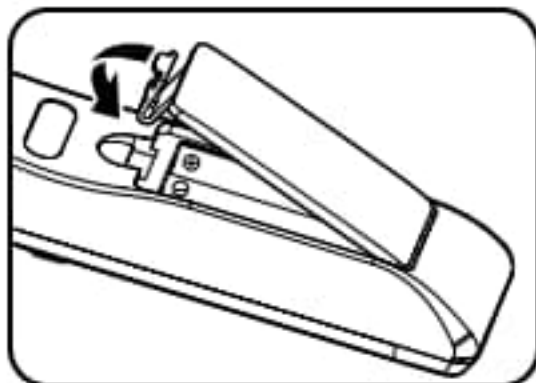

ATTENTION

The remote control may fail to operate if the infrared remote sensor is exposed to bright sunlight or fluorescent lighting.

Incorrect battery usage may cause leakage of battery fluid and battery rupture, which could result in fire, injury or corrosion of the remote. When replacing batteries, take the following precautions.

Do not use batteries of different types or mix old and new batteries.

Remove the batteries if you will not be using the projector for a long period of time.

Do not expose batteries to heat or flame and do not put them in water.

Dispose of used batteries according to local regulations.

Keep batteries out of the reach of children. Batteries are choking hazards and are very dangerous if swallowed.

7.3.2 REMOTE CONTROL IR CODES

NUMBER	FUNCTION	REPEATFORMAT	BYTE1	BYTE2	BYTE3	BYTE4	COMMENTS
1	AV mute	F1	87	4E	51	AE	
2	Power On/Off	F1	87	4E	17	EB	
3	Re-Sync	F1	87	4E	33	CC	
4	Up	F2	87	4E	13	EC	Do Volume+ when no OSD
5	Source	F1	87	4E	10	EF	
6	Left	F2	87	4E	11	EE	Do Source when no OSD
7	Enter	F1	87	4E	32	CD	
8	Right	F2	87	4E	12	ED	Do Re-Sync when no OSD
9	Menu	F1	87	4E	02	FD	
10	Down	F2	87	4E	14	EB	Do Volume- when no OSD
11	Eco	F1	87	4E	77	8B	Open Brightness Mode menu
12	Keystone+	F2	87	4E	20	DF	
13	Volume+	F2	87	4E	08	F7	
14	Keystone-	F2	87	4E	21	DE	
15	Volume-	F2	87	4E	04	FB	
16	VGA (1)	F1	87	4E	19	E6	
17	Video (2)	F1	87	4E	1A	E5	
18	HDMI (3)	F1	87	4E	71	8E	Toggle HDMI 1 and HDMI 2
19	Page+ (4)	F1	87	4E	7D	82	Page+ not supported
20	Aspect (5)	F1	87	4E	34	CB	
21	Zoom+	F1	87	4E	52	AD	
22	page- (7)	F1	87	4E	7E	81	Page- not supported
23	Freeze	F1	87	4E	0E	F1	
24	Zoom-	F1	87	4E	53	AC	
25	Mouse	F1	87	4E	3E	C1	Mouse not supported
26	Picture	F1	87	4E	2C	D3	Open Display Mode menu
27	Mute	F1	87	4E	29	D6	

7.4 REMOTE CONTROL EFFECTIVE RANGE

You can locate the infrared (IR) remote control sensors on the top of the projector next to the keypad and on the front to the left of the lens. Hold the remote control at an angle within 60 degrees perpendicular of the projector's IR remote control sensor. Ensure that there are no obstacles between the remote control and the IR sensor on the projector.

The distance between the remote control and the IR sensor should be less than 12 meters (39.4 feet). If the remote control is less than 20cm (8 inches) from the IR sensor, the remote control might become ineffective. The effective range is approximately 5 meters (16.4 feet) when reflecting the IR beam using a screen. The range will depend on the screen's surface and reflectivity. Direct sunlight or florescent lamps can reduce the range of the remote control.

7.5 TURNING THE PROJECTOR ON

1. Securely connect the mains cable to the projector and to a mains outlet. When connected, the Power LED will turn red.
2. Connect a signal/source cable to a source device and the projector.
3. Remove the lens cap.
4. Press the **Power** V2.0 02/2025 on the keypad or the  symbol on the remote control.

The InFocus startup screen will appear after approximately 10 seconds. The Power LED will flash blue and then steady blue.



ATTENTION

Make sure that people cannot step on any electrical cables or trip over the cables. Do not put objects on the cables.

7.6 SELECTING A INPUT SOURCE

1. Turn on the connected source, such as a computer or DVD player, or connect a digital media player, such as a Google Chromecast.
2. Press the **Source** button on the keypad or remote control to select the input source.
3. Play the content on the source device.



INFORMATION

You can set up the projector to automatically detect an active source and turn itself on and project the source content automatically. To turn on this feature, press the Menu button on the remote control or keypad, navigate to Settings > Power Settings > Signal Power, and select On.



INFORMATION

Your projector has a Direct Power On setting. This setting will automatically turn on the projector when a power source is connected. To turn on this feature, press the Menu button on the remote control or keypad, navigate to Settings > Power Settings > Direct Power On, and select on.

7.7 TURNING THE PROJECTOR TO STANDBY MODE

1. Press the **Power** button on the keypad or remote control.
The following message will appear: Power Off?
2. Press the **Power** button again to confirm turning off your projector.
If the **Power** button is not pressed a second time, the message will disappear after 10 seconds and the projector will not turn off.
The cooling fans will operate for about 10 seconds and the Power LED will flash blue. When the Power LED changes to solid red, the projector has entered standby mode.
3. Replace the lens cap.



INFORMATION

If you want to turn the projector on again, wait 100 seconds.

Always allow the projector fan to turn off after you power down and before you unplug the projector power cable from the electrical outlet.

7.8 VIEWING 3D CONTENT

Please follow all warnings and precautions as recommended before you or your child use the 3D function of this projector and view 3D projected content.



ATTENTION

Children and teenagers may be more susceptible to health issues associated with viewing in 3D and should be closely supervised when viewing 3D content.

7.8.1 PHOTSENSITIVE SEIZURE WARNING AND OTHER HEALTH RISKS



ATTENTION

- Some viewers may experience an epileptic seizure or stroke when exposed to specific flashing images or lights contained in certain Projector pictures or video games. If you suffer from or have a family history of epilepsy or strokes, please consult with a medical specialist before using the 3Dfunction.
- Even those without a personal or family history of epilepsy or stroke may have an undiagnosed condition that can cause photosensitive epileptic seizures.
- We recommend that the projectors 3D functionality not be used by pregnant women, sufferers of serious medical conditions, persons who are sleep-deprived or under the influence of alcohol.
- If you experience any of the following symptoms, stop viewing 3D content immediately and consult a medical specialist: (1) altered vision; (2) lightheadedness; (3) dizziness; (4) involuntary movements such as eye or muscle twitching; (5) confusion; (6) nausea; (7) loss of awareness; (8) convulsions; (9) cramps; or (10) disorientation. Children and teenagers may be more likely than adults to experience these symptoms. Parents should monitor their children and ask whether they are experiencing these symptoms.
- Watching 3D projected content may also cause motion sickness, perceptual aftereffects, disorientation, eye strain, and decreased postural stability. Users should take frequent breaks to lessen the potential of these effects. If you have any of the above symptoms, immediately discontinue using this device and do not resume using it for at least thirty minutes after the symptoms have subsided.
- Watching 3D projected content while sitting too close to the screen for an extended period may damage your eyesight. The ideal viewing distance should be at least three times the screen height. We recommend that the viewer's eyes are level with the screen.
- Watching 3D projected content while wearing 3D glasses for an extended period may cause headaches or fatigue. If you experience a headache, tiredness or dizziness, stop viewing the 3D projection and rest.
- Do not use 3D glasses for any other purpose than for watching 3D projected content.
- Wearing the 3D glasses for any other purpose (such as spectacles, sunglasses, protective goggles, etc.) may be physically harmful to you and weaken your eyesight.
- Viewing 3D projected content may cause disorientation for some viewers. Accordingly, **DO NOT** place your 3D projector near open stairwells, cables, balconies, or other objects that can be tripped over, run into, knocked down, broken or fallen over.

7.8.2 ENABELING 3D MODE

To enable 3D mode, the input frame rate should be set to 60Hz. Other frame rate are not supported. For the best 3D performance, use a resolution of 1920×1080. 4K (3840×2160) resolution is not supported in 3D mode.

1. Select **Display > Display Mode > 3D > 3D Mode**.
2. Select **On**.
If the 3D Mode is set to Off, the 2D-3D and 3D sync Invert functions will not be selectable. These functions can only be selected if the 3D mode is set to On.
3. Press **Enter**.
4. If you only want to view the left or right frame: Select **Display > Display Mode > 3D > 3D-2D**. Select **L** (left) or **R** (right). Press **Enter**.
5. If you want to turn off the 3D sync invert function:
 - Select **Display > Display Mode > 3D > 3D Sync Invert**.
 - Select **Off**.
 - Press **Enter**.

7.8.3 ENABLING AUTO 3D MODE

1. Select **Display > Display Mode > 3D > 3D Format**.
2. Select **Auto**.
3. Press **Enter**.

Other options:

- SBS: Display 3D signal in “Side-by-Side” format.
- Top and Bottom: Display 3D signal in “Top and Bottom” format.
- Frame Sequential: Display 3D signal in “Frame Sequential” format.

The multilingual On Screen Display (OSD) menus can be used to setup and adjust the projector.

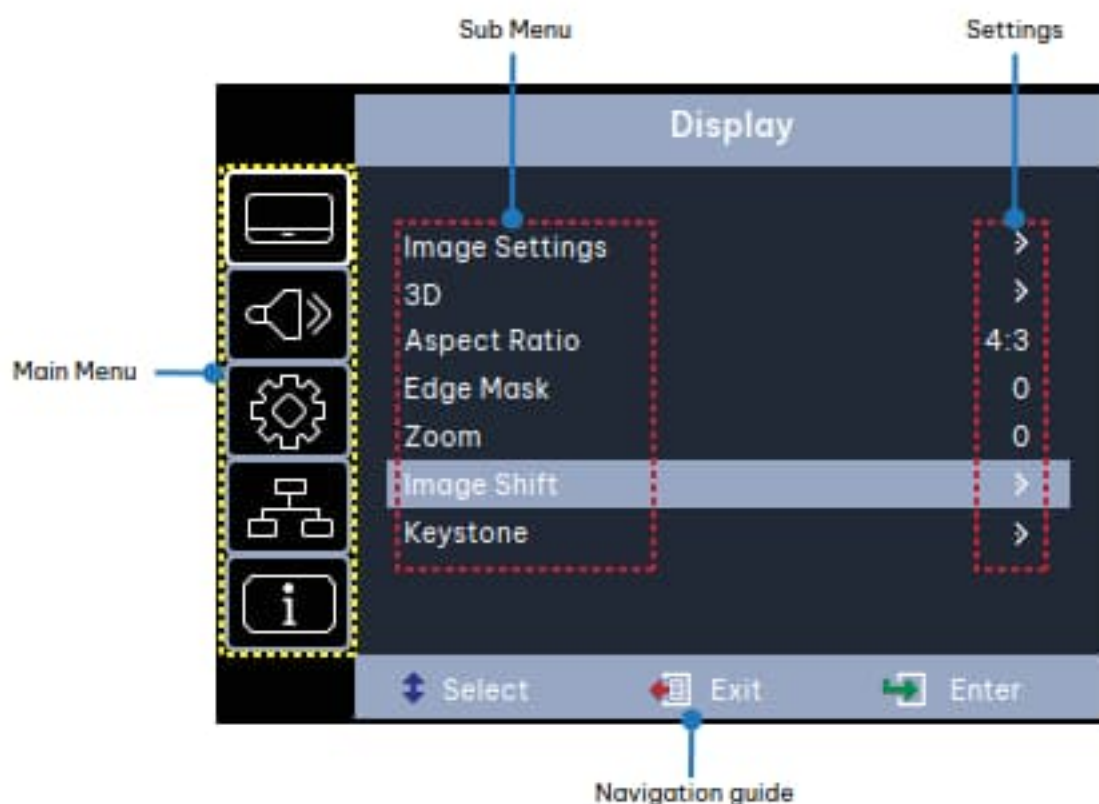

8.1 SELECTING THE LANGUAGE FOR THE ON SCREEN MENU

1. Select **Setup > Options > Language**
2. Select a language.
3. Press **Enter**.

8.2 SELECTING A DISPLAY MODE

1. Select **Display > Image Settings > Display Mode**.
2. Select a display mode:
 - **Presentation:** Suitable for giving presentations using a PC.
 - **Bright:** The brightest possible setting when using a PC.
 - **HDR SIM.:** Decodes and displays High Dynamic Range (HDR) content for the deepest blacks, brightest whites, and vivid cinematic colour using the REC.2020 colour gamut. This mode will be automatically enabled if HDR content is sent to the projector (4K UHD Blu-ray, 1080p/4K UHD HDR/HLG games, or 4K UHD streaming video). While HDR mode is active, other displays cannot be selected as HDR delivers colour that is highly accurate and exceeds the colour performance of the other display modes. HDR mode can also be manually selected for use with non HLG content for simulation effect.
 - **HLG SIM.:** Decodes and displays Hybrid Log Gamma (HLG) content for the deepest blacks, brightest whites, and vivid cinematic colour using the REC.2020 colour gamut. This mode will be automatically enabled if HLG content is sent to the projector (4K UHD Blu-ray, 1080p/4K UHD HDR/HLG games, or 4K UHD streaming video). HLG mode can also be manually selected for use with non HLG content for simulation effect.
 - **Cinema:** Provides the best colour reproduction for watching movies.

- **Game:** Increases the brightness and decreases the response time for playing video games with minimal lag.
- **sRGB:** Standardized accurate colour reproduction.
- **DICOM SIM.:** Simulation mode for viewing monochrome images such as X-rays.
- **User:** Saved user settings.
- **3D:** To experience 3D, you will need 3D glasses and a video source that is capable of sending 3D content.

3. Press **Enter**.



INFORMATION

The display settings are only visible when an active source is connected to the projector.

8.3 ADJUSTING THE IMAGE COLOUR AND TEMPERATURE

1. Select **Display > Image Settings > Color Settings > Color Temperature**.
2. Select a value.
3. Press **Enter**.



INFORMATION

The display settings are only visible when an active source is connected to the projector.

8.4 ADJUSTING THE SHARPNESS OF THE IMAGE

1. Select **Display > Image Settings > Color**.
2. Press **Enter**.

8.5 MAGNIFYING THE IMAGE

1. Select **Display > Zoom**.
2. Press **Enter**.

8.6 SELECTING AN ASPECT RATIO

1. Select **Display > Aspect Ratio**.
2. Select the desired aspect ratio.
3. Press **Enter**.

8.7 ADJUSTING THE BRIGHTNESS

1. Select **Display > Image Settings > Brightness Mode**.
2. Select a brightness mode.
3. Press **Enter**.

8.8 ENABELING ECO MODE

1. Select **Display** > **Image Settings** > **Brightness Mode**.
2. Select **Eco**.
3. Press **Enter**.

8.9 ENABLING CLOSED CAPTIONS

1. Select **Setup** > **Options** > **Closed Caption**.
2. Select **CC1** or **CC2**.
3. Press **Enter**.

8.10 DISPLAYING A TEST PATTERN

1. Select **Setup** > **Test Pattern**.
2. Select a test pattern.
3. Press **Enter**.

8.11 PREVENTING UNAUTHORIZED USE

1. Select **Setup** > **Security** > **Security**.
2. Select **On**. The default password is 1234.
3. Press **Enter**.

8.12 CHANGING THE PASSWORD

1. Select **Setup** > **Security** > **Change Password**.
2. Type the new password.
3. Press **Enter**.



INFORMATION

Do not lose the password. The password can only be reset at an authorized InFocus repair facility.

8.13 CONTROLLING THE PROJECTOR FROM A WEB BROWSER

1. Connect the projector to an active network port using the RJ45 port on the back of the projector.
2. Select **Network > LAN > DHCP**.
3. Select **On**.
4. Press **Enter**.
5. Select **Network > LAN > IP Address** to view the projector's IP address.
6. Open a web browser.
7. Type the projector's IP address type the user name and password. The default user name and password is **admin**.
8. Click **Login**. The projector's configuration page appears.



INFORMATION

This section is only applicable to p122 and p123 Vista II products.

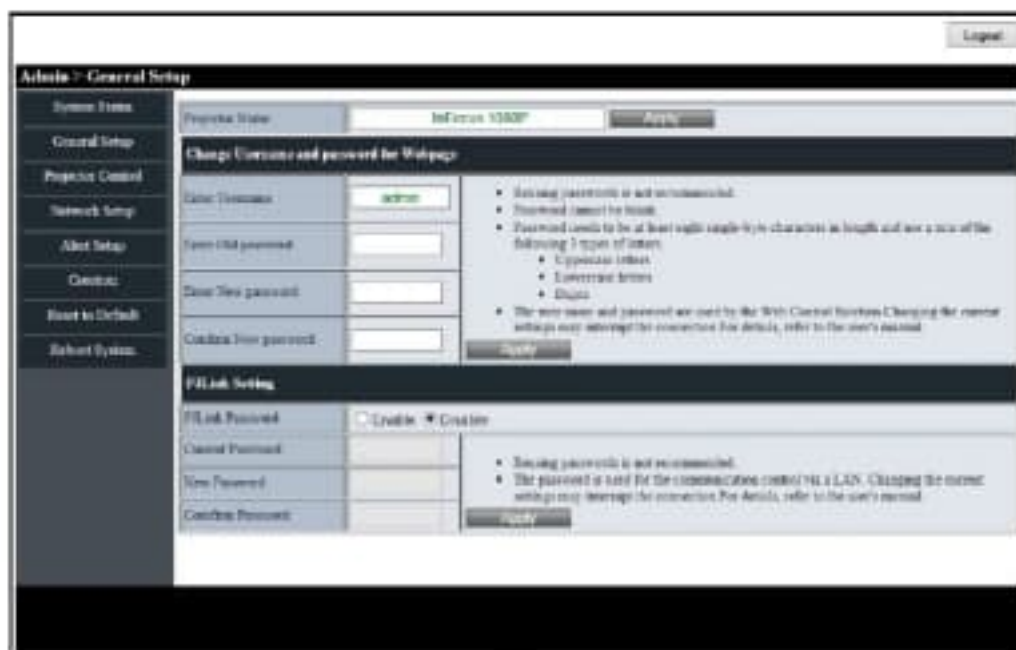

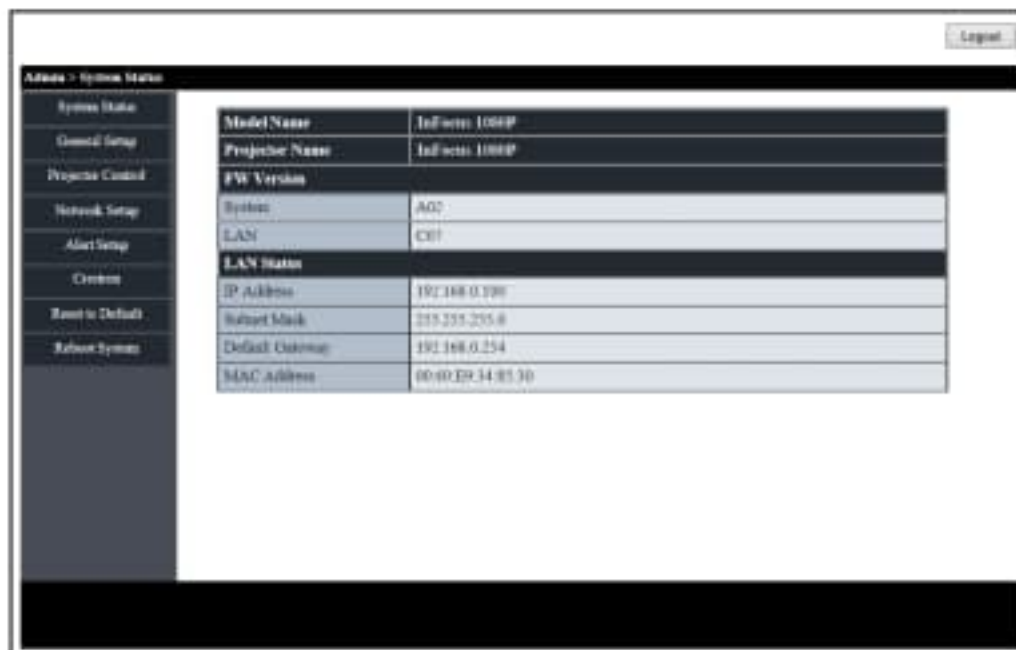

Web Control Aspect Ratio Support list below

Aspect Ratio	XGA	WXGA	1080P
4:3	✓	✓	✓
16:9	✓	✓ (Follow OSD->Screen Type)	✓
16:10		✓ (Follow OSD->Screen Type)	
LBX		✓	✓
Native	✓	✓	✓
AUTO	✓	✓	✓

Notice If web page select the unsupport aspect ratio, projector will do nothing and the web will show the aspect ratio same with OSO.

The aspect ratio of WXGA model will change dueto the screen type setting.

IP Address	192	168	0	801
Subnet Mask	255	255	255	0
Default Gateway	192	168	0	254
DNS Server	192	168	0	81

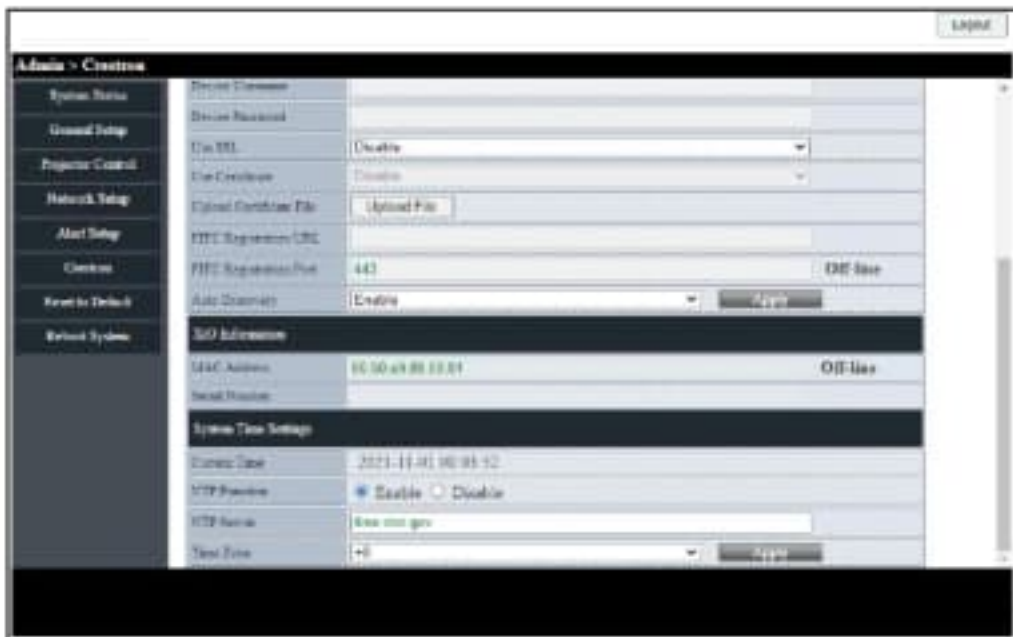
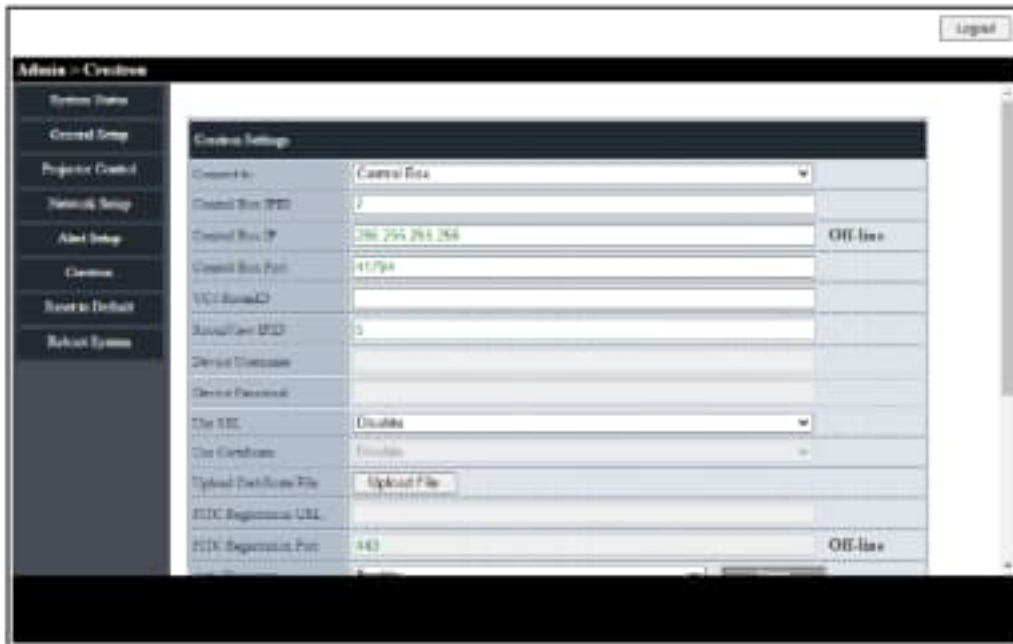

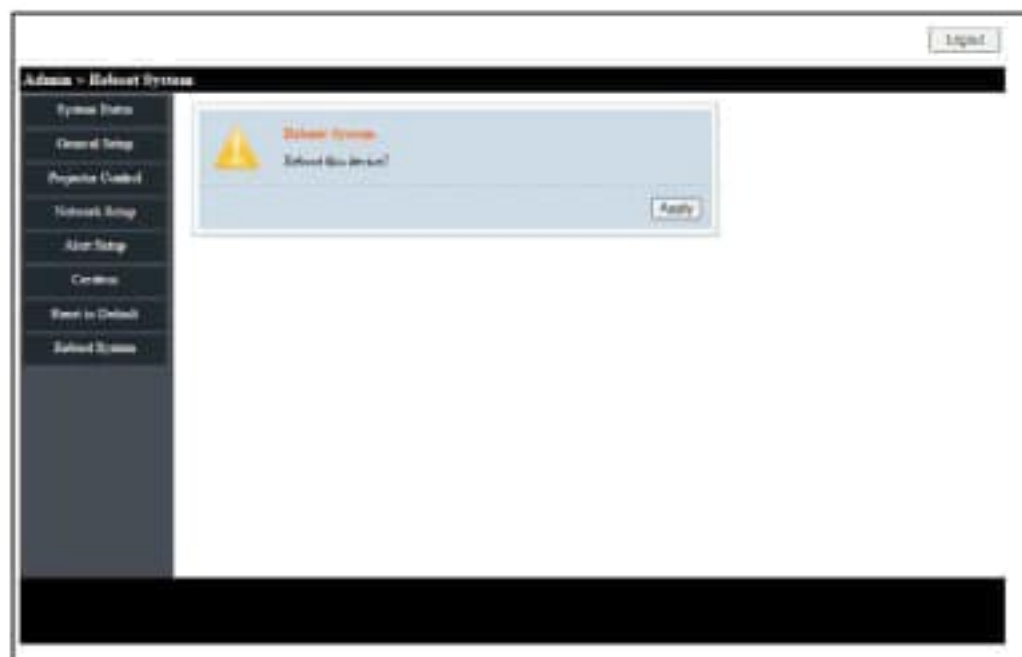

INFORMATION

Only applicable to Superior Series.

8.14 DIRECTLY CONNECTING A COMPUTER TO THE PROJECTOR

1. Select **Network > LAN > DHCP**.
2. Select **Off**.
3. Press **Enter**.
4. Select **Network > LAN**.
5. Configure the IP address, Subnet Mask, Gateway, and DNS settings.
6. Set the computer to use the same IP address, subnet mask, gateway, and DNS settings.
7. Open a web browser.
8. Type the projector's IP address type the user name and password. The default user name and password is **admin**.



INFORMATION

Only applicable to Superior Series.

9. CLEANING

Do not use canned air or any type of abrasive pad, paper towel, scouring powder, glass cleaner, or solvent (such as alcohol, paint thinner or benzene).

Unplug the projector before cleaning.

9.1 CLEANING THE LENS

Clean the projector's lens with a lightly damp cloth. Do not spray liquid directly onto the lens.

9.2 CLEANING THE CASE

Clean the projector's case using a lightly damp cloth.

9.3 CLEANING THE AIR VENTS

Clean the air intake vents with a soft and dry cloth, a soft brush, or a small vacuum cleaner designed for cleaning electrical devices.

10. SANITATION

- Using only lightly dampened microfibre cloth to avoid malfunction and possible permanent damage to electronic parts, lightly clean the surface of the product, avoiding any connection points, ventilation holes or the lens.
- After the application, dry the product with a clean and dry microfibre cloth.

Please follow all safety and handling instructions listed with the cleaning solution and keep out of reach of children. For schools conducting an overall deep clean of their facilities, here are steps to appropriately protect your InFocus product in advance of chemicals being sprayed or fogging devices being employed:

- Disconnect the product from its power source.
- Cover the product to prevent damage to internal electronic components.
- Remember to remove any covering before use.

Please ensure that those with access to your InFocus products are aware of the cleaning procedure.



ATTENTION

Ensure your InFocus product is fully covered on all sides before facilities deep cleaning. Chemicals must not be allowed to enter or be sprayed on to the surface of the product, this will avoid any damage to the internal electronic components and outer casing parts.



INFORMATION

Good personal hygiene practices of washing and drying hands should be employed before and after use of InFocus products.

Should you have any questions relating to these procedures please contact InFocus Technical Support. Contact details can be found [Here](#).

11. DISPOSAL

11.1 DISPOSAL OF ELECTRICAL COMPONENTS



The symbol on the product, the accessories or packaging indicates that this device shall not be treated as unsorted municipal waste, but shall be collected separately. Dispose of the device via a collection point for the recycling of waste electrical and electronic equipment if you live within the EU and in other European countries that operate separate collection systems for waste electrical and electronic equipment. By disposing of the device in the proper manner, you help to avoid possible hazards for the environment and public health that may otherwise be caused by improper treatment of waste equipment. The recycling of materials contributes to the conservation of natural resources.

11.2 DISPOSAL OF PACKAGING WASTE

The packaging is made of environmentally friendly materials, which may be disposed of through your local recycling facilities. By disposing of the packaging and packaging waste in the proper manner, you help to avoid possible hazards for the environment and public health.

12.1 LED INDICATOR LIGHTS

The following table describes the LED indicator light colours and their meaning.

LED	INDICATOR	MEANING
Power	Blue solid	Normal operation
Power	Blue flashing	The projector is warming up, shutting down, or cooling down. The remote control may be disabled while the indicator is flashing blue.
Power	Red solid	Standby mode
Power	Off	Off or Sleep mode
Lamp	Red flashing	lamp failure
Temperature	Red flashing	Fan failure
Temperature	Red solid	Over temperature

The projector will automatically shutdown if there is a laser failure, a fan failure or if the projector has overheated. Unplug the power cable from the projector, wait 30 seconds, and try again. If the warning indicators light up or flash, contact your nearest service center for assistance.

12.2 SOLVING ON / OFF ISSUES

The following table provides solutions for potential issues that may occur when the projector is turned on or off.

ISSUE	CAUSE	SOLUTION
Projector will not turn on.	No power	Check that the power cable is connected. Check that the power indicator is on.
Projector will not turn on.	The projector has overheated	Make sure there is at least 30cm of clearance around the intake and exhaust vents. Wait five minutes and try turning the projector on again. If the projector is being used above 5500 ft/1600 m, use the On Screen Display (OSD) menu to set High Altitude to on.
Projector turns off by itself.	The Auto Power Off timer is set	Use the On Screen Display (OSD) menu to adjust the auto power of setting.

12.3 SOLVING IMAGE ISSUES

The following table provides solutions for potential image issues.

ISSUE	CAUSE	SOLUTION
No image	Incorrect source is selected.	Press the SOURCE button or one of the source buttons again.
No image	Source cable is not connected.	Ensure the source cable is securely connected to the projector and source device
No image	Source is not playing	Make sure the source has not stopped or paused the video. If the source is a computer, make sure the PC is not in a screen saving or power saving mode and resend the video to the projector.
No image	AV-Mute is on	Ensure the AV-MUTE (video off) buttons has not been pressed.
No image	Brightness and/or contrast setting is too low	Use the On Screen Display (OSD) menu to adjust the brightness and contrast
Image is reversed	Orientation is set incorrectly.	Use the On Screen Display (OSD) menu to adjust the orientation.
Image has slanted sides	Projector is not positioned perpendicularly to the screen.	Ensure the projector is centered on the screen and below the bottom of the screen
Image has slanted sides	Keystone is not set correctly.	Press the keystone + or - buttons to adjust the image alignment.

ISSUE	CAUSE	SOLUTION
Image is too small or too large.	Projector is too far from or too close to the screen.	Move the projector
Image is too small or too large.	The zoom is not set correctly.	Press the Zoom + or - buttons to adjust the zoom.
Image is too dark	ECO mode is enabled	Check if the projector is in the Forced ECO mode because the ambient temperature is too high.
Image is blurry	Focus is not set correctly.	Use the focus ring to adjust the focus.
Image is blurry	Projector is too close or too far from the screen.	Ensure that the distance between the projector and screen is within the adjustment range of the lens.
Image is blurry	Smudge or condensation on the lens.	Clean the lens. Condensation may form on the lens if the projector is cold, brought into a warm place, and turned on.
Image is scrolling or flickering.	Source resolution and/or frequency is not supported.	Make sure that the source's resolution and frequency are supported by the projector.

12.4 SOLVING VIDEO, AUDIO AND REMOTE CONTROL ISSUES

The following table provides solutions for potential video, audio, and remote control issues.

ISSUE	CAUSE	SOLUTION
Video is frozen	The Freeze button has been pressed.	Press the Freeze button on the remote to unfreeze the video.
Video is stretched	16:9 (wide) source is setup incorrectly.	Ensure the source is set to use the 16:9 (wide) display format.
Video is stretched	Letterbox (LBX) source is setup incorrectly.	Use the On Screen Display (OSD) menu to set the aspect ratio to LBX.
Video is stretched	4:3 source is setup incorrectly.	Use the On Screen Display (OSD) menu to set the aspect ratio to 4:3.
No audio	Projector is muted.	Press the Mute button to unmute the projector.
No audio	Volume setting is too low.	Press the volume + button to increase the volume.
No audio	Source cable is not connected.	Ensure the source cable is securely connected to the projector and source device.
No audio	Source is muted.	Ensure the source has not been muted.
Remote does not work.	Batteries expired.	Install new batteries.
Remote does not work.	Batteries installed incorrectly.	Remove and reinstall the batteries.
Remote does not work.	Remote is too far from projector.	The remote should be within 16.4 feet (5m) of the projector.
Remote does not work.	IR receiver cannot detect remote.	Ensure there are no obstructions between the remote and the projector's IR receiver. Ensure the operating angle of the remote control is within $\pm 20^\circ$ to the projector's IR receiver. Ensure there are no fluorescent light sources shining on the projector's IR receiver.

If you are still experiencing technical issues with your projector, please contact InFocus Customer Support [Here](#).

12.5 SERVICING

Servicing is required when the projector has been damaged, exposed to rain or moisture, does not operate normally, or has been dropped. All servicing and repairs should be performed by an authorized InFocus representative.

13.1 RS232 PIN ASSIGNMENTS

PIN NUMBER	BO DETAILED TIMING
1	-
2	RDX
3	TXD
4	-
5	GND
6	-
7	-
8	-
9	-

13.2 RS232 PROTOCOL FUNCTION LIST

FUNCTION	VALUE
BAUD RATE	1920
PARITY BIT	NONE
DATA BIT	8
STOP BIT	1
LASER ON DELAY	20 SECONDS
POWER DOWN DELAY	20 SECONDS
SOURCE CHANGE DELAY	8 SECONDS
INTERCOMMAND DELAY MINIMUM	500 MILLISECONDS
INTERCHARACTER DELAY MINIMUM	2 MILLISECONDS

13.3 SUPPORTED RESOLUTIONS AND REFRESH RATES

Video Compatibility

NTSC	NTSC M/J, 3.58MHz, 4.43MHz
PAL	PAL B/D/G/H/I/M/N, 4.43MHz
SECAM	SECAM B/D/G/K/K1/L, 4.25/4.4 MHz
SDTV	480i/p, 576i/p
HDTV	720p(50/60Hz), 1080i(50/60Hz), 1080P(50/60Hz)

Note Video timing detail

SIGNAL	RESOLUTION	REFRESH RATE (Hz)	NOTES
TV (NTSC)	720×480	60	For Composite Video /S-video
TV (PAL_SECAM)	720×576	50	
SDTV (480i)	720×480	60	For Component
SDTV (480P)	720×480	60	
SDTV (576i)	720×576	50	
SDTV (576P)	720×576	50	
HDTV (720p)	1280×720	50/60	
HDTV (1080i)	1920×1080	50/60	
HDTV (1080p)	1920×1080	24/50/60	

True 3D Video Compatibility table

INPUT RESOLUTIONS	HDMI 1.4a 3D Input	Input timing		
		1280×720P @ 50Hz	Top-and-Bottom	
		1280×720P @ 60Hz	Top-and-Bottom	
		1280×720P @ 50Hz	Frame packing	
		1280×720P @ 60Hz	Frame packing	
		1920×1080i @50 Hz	Side-by-Side (Half)	
		1920×1080i @60 Hz	Side-by-Side (Half)	
		1920×1080P @24 Hz	Top-and-Bottom	
		1920×1080P @24 Hz	Frame packing	
	HDMI 1.3	1920×1080i @ 50Hz	Side-by-Side(Half)	SBS mode is on
		1920×1080i @ 60Hz		
		1280×720P @50Hz		
		1280×720P @60Hz		
		800×600 @ 60Hz		
		1024×768 @ 60Hz		
		1920×1080i @ 50Hz	Top-and-Bottom	TAB mode is on
		1920×1080i @ 60Hz		
		1280×720P @50Hz		
		1280×720P @60Hz		
	800×600 @ 60Hz			
	1024×768 @ 60Hz			
		480i	HQFS	3D format is Frame sequential

If 3D input is 1080p@24Hz, the DMD should replay with integral multiple with 3D mode Support NVIDIA 3DTV Play if there is no patent fee from InFocus

Note 1080i@25Hz and 720p@50Hz will run in 100Hz; other 3D timing will run in 120Hz.

VESA standards Computer Signal (Analog RGB Compatible)

SIGNAL	RESOLUTION	REFRESH RATE(HZ)	NOTES FOR MAC
VGA	640*480	60/67/ 72/85	Mac 60/ 72/85/
SVGA	800*600	56/60 (*2)/ 72/85/120 (*2)	Mac 60/ 72/85
XGA	1024*768	48/50/60 (*2)/ 70/ 75/85/120 (*2)	Mac 60/ 70/ 75/85
HDTV(720P)	1280*720	50/60 (*2)/120 (*2)	Mac 60
WXGA	1280*768	60/ 75/85	Mac 60/ 75/85
	1280*800	48/50/60	Mac 60
WXGA (*3)	1366*768	60	
SXGA	1280*1024	60/ 75/85	Mac 60/ 75
SXGA+	1400*1050	60	
UXGA	1600*1200	60	
HDTV(1080p)	1920*1080	24/50/60	Mac 60
WUXGA	1920*1200 (*1)	60/50hz	Mac 60

(*1) 1920*1200 @60Hz only support RB (reduced blanking)

(*2) Support 3D timing for 3D Ready projector (STD) and True 3D projector (Option)

(*3) Window 10 standard timing

13.4 ON SCREEN DISPLAY (OSD) MENU TREE

IMAGE

SETTING 1	SETTING 2	SETTING 3	VALUES	COMMENTS
Picture Mode			Presentation	1. RGB source default: Presentation 2. YUV source default: Movie 3. 3D on default: 3D 4. ISF Day and ISF Night are valid while ISF Mode is On or Unlock
			Bright	
			Movie	
			sRGB	
			DICOM SIM.	
			User	
			3D	
			ISF Day	
Wall Colour			Whiteboard	
			Blackboard	
			Light Yellow	
			Light Green	
			Light Blue	
			Pink	
			Gray	
Brightness			-50 - 50	
Contrast			-50 - 50	
Sharpness			1 - 15	
Colour			-50 - 50	Only for YUV source
Tint			-50 - 50	Only for YUV source

SETTING 1	SETTING 2	SETTING 3	VALUES	COMMENTS	
Advanced	Gamma		Film	1. Picture Mode is DICOM SIM. Gamma item will be hide. 2. Wall Colour is Blackboard. Gamma item will be hide.	
			Video		
			Graphics		
			Standard (2.2)		
			1.8		
			2.0		
	BrilliantColor™			1 - 10	
		Colour Temp		Warm	
				Medium	
			Cold		
	Colour Settings		Red- Hue	-50 - 50	
			Red- Saturation	-50 - 50	
			Red- Gain	-50 - 50	
			Exit		
			Green- Hue	-50 - 50	
			Green- Saturation	-50 - 50	
			Green- Gain	-50 - 50	
			Exit		
			Blue- Hue	-50 - 50	
			Blue- Saturation	-50 - 50	
			Blue- Gain	-50 - 50	
			Exit		
			Cyan- Hue	-50 - 50	
			Cyan- Saturation	-50 - 50	
			Cyan- Gain	-50 - 50	
			Exit		
			Magenta- Hue	-50 - 50	
			Magenta- Saturation	-50 - 50	
			Magenta- Gain	-50 - 50	
			Exit		
			Yellow- Hue	-50 - 50	
			Yellow- Saturation	-50 - 50	
			Yellow- Gain	-50 - 50	
Exit					
White- Red	-50 - 50				
White- Green	-50 - 50				
White- Blue	-50 - 50				
Exit					
Reset					
Exit					

SETTING 1	SETTING 2	SETTING 3	VALUES	COMMENTS	
Advanced	RGB Gain/Bias	Red Gain	-50 - 50		
		Green Gain	-50 - 50		
		Blue Gain	-50 - 50		
		Red Bias	-50 - 50		
		Green Bias	-50 - 50		
		Blue Bias	-50 - 50		
		Reset			
		Exit			
	Colour Space			AUTO	
				RGB	Only for non-HDMI source
				RGB (0-255)	Only for HDMI source
				RGB (16-235)	Only for HDMI source
				YUV	
	White Level			0 - 31	Only for Video
	Black Level			-5 - 5	Only for Video
	IRE			0	For Video Input Source NTSC Signal default: 7.5 PAL. Signal default: 0 IRE Adjustment Only for NTSC-M/NTSC-J/NTSC-4.43/PAL-M/PAL-60
				7.5	
	Signal	Automatic		Off	Only for Analog VGA source
				On	
		Phase		0 - 31	
		Frequency		-10 - 10	
		H. Position		-5 - 5	
		V. Position		-5 - 5	
Exit					
Exit					

Display



INFORMATION

Zoom has a total of 30 step adjustment, each step representing 0.04* adjustment from -0.8 to 2.0* Brightness Power, each step represents 5% power adjustment from 100% to 50%.

SETTING 1	SETTING 2	SETTING 3	VALUES	COMMENTS
Format			4:3	
			16:9	For all models but WXGA models depend on Screen Type selection
			16:10	Only for WXGA models depend on Screen Type selection
			LBX	Only for WXGA, 1080p models.
			Native	Original image without any scaling
			Auto	
Edge Mask			0 - 10	
Zoom			-5 - 25	

SETTING 1	SETTING 2	SETTING 3	VALUES	COMMENTS
Image Shift	H		-100 - 100	One step: 2
	V		-100 - 100	One step: 2
	Exit			
V Keystone			-40 - 40	for RT
			-20 - 20 (TBD)	for ST Note: the V keystone range of 1080p ST: -10-10 in 3D mode by DDP4422 limitation
3D	3D Mode		Off	
			DLP-Link	
	3D-2D		3D	
			L	Only display left frame
		R	Only display right frame	
	3D Format		Auto	
			SBS	SBS = Side by Side Half
			Top and Bottom	
	3D Sync. Invert		Frame Sequential	
			Off	
		On		
	Exit			
Enhanced Gaming			Off	1. Only for 1920x1080 60Hz timing 2. Disable Keystone/Overscan/Zoom/Image Shift/Aspect Ratio when turn On
			On	
Picture Mode Lock			Off	
			On	

Audio

SETTING 1	SETTING 2	SETTING 3	VALUES
Mute	-	-	Off / On (ICON)
Volume	-	-	0-10

Setup



INFORMATION

Power Mode, Eco/Active – Eco disables LAN and puts USB in to standby mode, Active leaves LAN active and USB in to standby.

SETTING 1	SETTING 2	SETTING 3	VALUES	REMARK
Language			English	English
			Deutsch	German
			Français	French
			Svenska	Swedish
			Español	Spanish
			Português	Portuguese
			Polski	Polish
			Nederlands	Dutch
			हिंदी	Hindi
			Norsk/Dansk	Norwegian/Danish
			Pilipino	Filipino
			Melayu	Malay
			Română	Romanian
			Italiana	Italian
			簡體中文	Simplified Chinese
			Suomi	Finnish
			ελληνικά	Greek
			Русский	Russian
			Magyar	Hungarian
			Čeština	Czech
			العربية	Arabic
ไทย	Thai			
Türkçe	Turkish			
فارسی	Farsi			
Tiếng Việt	Vietnamese			
Bahasa Indonesia	Indonesian			
বাংলা	Bengali			
Projection			Front (ICON)	
			Rear (ICON)	
			Front-Ceiling (ICON)	
			Rear-Ceiling (ICON)	
Menu Location			Top-Left (ICON)	
			Top-Right (ICON)	
			Center (ICON)	
			Bottom-Left (ICON)	
			Bottom-Right (ICON)	
Screen Type			16:10	1. Only for WXGA models 2. Relate to Format
			16:9	

SETTING 1	SETTING 2	SETTING 3	VALUES	REMARK
Security	Security		Off	Default PIN: 1234
			On	
	Security Timer	Month	0 - 12	
		Day	0 - 30	
		Hour	0 - 24	
Change Password			PIN is 4 digits	
Project ID			0 - 99	
Audio Settings	Mute		Off	
			On	
	Volume		0 - 10	
	Audio Input		Default	Only for HDMI source
			AUDIO IN	
Exit				
HDMI Link Settings	HDMI Link		Off	
			On	
	Power On Link		Mutual	
			PJ -> Device	
			Device -> PJ	
	Power Off Link		Off	
		On		
Network	Network State		Connect/Disconnect	DHCP Off, default IP configure setting: IP Address: 192.168.0.100 Subnet Mask: 255.255.255.0 Gateway: 192.168.0.254 DNS: 192.168.0.1 Support Network Functions: Crestron 2.0 => Port 41794 Extron => Port 2023 AMX Device Discovery => Port 9131 PJ Link => Port 4352 Telnet => Port 23 HTTP => Port 80, Webpage Control
	DHCP		Off	
			On	
	IP Address		xxx.xxx.xxx.xxx	
	Subnet mask		xxx.xxx.xxx.xxx	
	Gateway		xxx.xxx.xxx.xxx	
	DNS		xxx.xxx.xxx.xxx	
	Apply	Yes		
No				
Exit				
Advanced	Logo		Default	
			Neutral	Same as below Background Colour setting
	Background Colour		Black	
			Red	
			Blue	
			Green	
			White	
			Logo	
	Information Hide		Off	Warning message & power off not hide
			On	
Exit				

OPTIONS

SETTING 1	SETTING 2	SETTING 3	VALUES	COMMENTS	
Input Source			VGA		
			Video		
			HDMI 1		
			HDMI 2		
Auto Source			Exit		
			Off		
High Altitude			On		
			Off		
Keypad Lock			Off	1. Keypad unlock hotkey: Press the "Enter" key on keypad for 5s to release keypad lock 2. Relate to IR Function: If Keypad Lock setting from Off to On, IR Function will be automatically changed to On.	
			On		
Test Pattern			Red Grid		
			Green Grid		
			Blue Grid		
			White		
Remote Settings	IR Function		Off	Relate to Keypad Lock: If IR Function setting from On to Off, Keypad Lock will be automatically changed to Off.	
			On		
	User 1			AV Mute	Executed through the AV "Mute" key on the remote control
				Wall Colour	
				Brightness	
				Contrast	
				Gamma	
				Colour Temp.	
				Colour Settings	
				RGB Gain/Bias	
				Language	
				Projection	
				Security	
				Test Pattern	
				Auto Power Off (min)	
				Sleep Timer (min)	
				Lamp Settings	
INFO					
Advanced	Direct Power On		Off		
			On		
	Signal Power On			Off	
				On	
	Auto Power Off (min)			0 - 180	One step: 5
	Sleep Timer (min)			0 - 990	One step: 30

SETTING 1	SETTING 2	SETTING 3	VALUES	COMMENTS
Advanced	Quick Resume		Off	
			On	
	VGA Out (Standby)		Off	
			On	
	USB Power		Off	Standby not supported
On				
Exit				
Lamp Settings	Lamp Hours		(DisplayOnly)	Range 0-99999
	Lamp Reminder		Off	
			On	
	Brightness Mode		Bright	
			Eco	
			Dynamic	
	Lamp Reset		No	
Yes				
Exit				
Reset			No	
			Yes	

Information



INFORMATION

The information menu provides information on the active source and other details of the projector, there are no adjustable settings in this section of the menu.

SETTING 1	SETTING 2	SETTING 3	VALUES	COMMENTS
Regulatory			P122 for RT P123 for ST	
Serial Number			(DisplayOnly)	
Input Source			(DisplayOnly)	
Resolution			(DisplayOnly)	
Refresh Rate			(DisplayOnly)	
Picture Mode			(DisplayOnly)	
Lamp Hours	Bright		(DisplayOnly)	Range 0-99999
	Eco		(DisplayOnly)	Range 0-99999
	Dynamic		(DisplayOnly)	Range 0-99999
	Total		(DisplayOnly)	Range 0-99999
Brightness Mode			(DisplayOnly)	
Firmware Version	System		(DisplayOnly)	
	MCU		(DisplayOnly)	
Project ID			(DisplayOnly)	

14. SPECIFICATIONS



INFORMATION

All specifications are subject to change without notice.

14.1 VISTA II, P122 & P123, SPECIFICATIONS

	IN0044SL	IN00465L	IN00485L	IN0044ST	IN00465T	IN00485T
IMAGE						
Product Series	VISTA II					
Display Technology	Texas Instruments DLP*					
Panel Size	0.55" DMD	0.65" DMD	0.65" DMD	0.55" DMD	0.65" DMD	0.65" DMD
Native Resolution	XGA	WXGA	1080p	XGA	WXGA	1080p
Pixels	1024×768	1280×800	1920×1080	1024×768	1280×800	1920×1080
Aspect Ratio	4:3	16:10	16:9	4:3	16:10	16:9
Contrast Ratio	30000:1					
Brightness (Lumens)	4600	4700	4400	4200	4300	4000
Light Source	UHP Lamp					
Light Source Life Maximum Hours	15000					
Maximum Supported Resolution	1920×1200					
Horizontal Sync. Range (KHz)	15 - 97.55					
Vertical Sync. Range (Hz)	54 - 85					
Uniformity (%)	80					
LENS						
Lens	1.3*			1:1 Fixed		
Lens Zoom Adjustment	Manual			-		
Image Offset (%)	115	112.4	116	115	112.4	116
Focal Length (mm)	21.85 - 24.01			7.15		
F-Stop	2.43	2.7	2.43	2.8	2.43	2.8
Keystone Adjustment	Manual/Automatic					
Vertical Keystone Correction	± 40°			± 20°		
Projection Factor	1.48-1.93:1	1.19-1.54:1	1.13-1.47:1	0.617:1	0.521:1	0.496:1
Projection Distance (Meters/Feet)	1.0 - 9.1 / 3.28 - 29.85	1.0 - 7.7 / 3.28 - 22.26	1.0 - 10.0 / 3.28 - 32.80	0.4 - 3.8 / 1.31 - 12.46	0.4 - 3.4 / 1.31 - 11.15	0.4 - 3.3 / 1.31 - 10.82
Optical Zoom	1.3:1			1:1		
Digital Zoom Demagnification / Magnification	0.8* - 2.0*					
Focus Adjustment	Manual					
CONNECTIVITY—INPUTS						
Mini D-sub 15-pin (VGA)	<input checked="" type="checkbox"/>					
Composite Video	<input checked="" type="checkbox"/>					
S-Video	-					
HDMI™ 1.4	<input checked="" type="checkbox"/> <input checked="" type="checkbox"/>					
RJ45 - LAN 10/100/1000	<input checked="" type="checkbox"/>					
3.5 mm Stereo Mini Jack	<input checked="" type="checkbox"/>					

	IN0044SL	IN0046SL	IN0048SL	IN0044ST	IN0046ST	IN0048ST
CONNECTIVITY – OUTPUTS						
Mini D-sub 15-pin (VGA)			☑			
3.5 mm Stereo Mini Jack			☑			
Powered USB-A for Wireless Dongle			☑			
CONNECTIVITY - OTHER						
RS232			☑			
All Major 3D Formats			☑			
USB-A for Service			☑			
POWER						
Power Supply	100 - 240 V AC; 50 - 60 Hz					
Power Consumption Max (W)	267					
Power Consumption Min. (W)	210					
Power Consumption Network Standby (W)	<2.0					
Power Consumption Standby (W)	<0.5					
GENERAL						
Product Dimensions (L x W x H) (mm / in)	313 x 236 x 96.4 / 12.4 x 9.3 x 3.8					
Product Weight (Kilograms/Pounds)	2.9 / 6.4					
Packaged Dimensions (L x W x H) (mm / in)	395 x 337 x 166 / 15.6 x 13.3 x 6.5					
Packaged Weight (Kilograms/Pounds)	4.1 / 9.0					
Fan Noise (dB)	27					
Audio (W)	1 x 10					
Operating Temperature (Celsius/ Fahrenheit)	5 - 40 / 41 - 104					
Operating Humidity (%)	10 - 85					
Max Operating Altitude (meters / feet)	3048 / 10000					
Storage Temperature (Celsius/Fahrenheit)	-10 - 60 / 14 - 140					
Storage Humidity (%)	10 - 85					
Security	Kensington Security Slot™, PIN Code Lock & Timer					
Safety and Regulatory	CB, CE, EAC, cTUVus, CCC, FCC, UKCA, NOM, PSB, BIS					
Environmental	WEEE, EU RoHS, China RoHS, CEL, CECP					
IN THE BOX						
Projector	☑	☑	☑	☑	☑	☑
Simplified Users Guide	☑	☑	☑	☑	☑	☑
VGA Cable	☑	☑	☑	☑	☑	☑
Regional Power Cord	☑	☑	☑	☑	☑	☑
Remote Control (no Battery)	☑	☑	☑	☑	☑	☑

14.2 GENESIS III, P124, SPECIFICATIONS

	IN0002SL	IN0004SL	IN0006SL
IMAGE			
Product Series	GENESIS III		
Display Technology	Texas Instruments DLP®		
Panel Size	0.55" DMD		0.65" DMD
Native Resolution	SVGA	XGA	WXGA
Pixels	800×600	1024×768	1280×800
Aspect Ratio	4:3		16:10
Contrast Ratio	30000:1		
Brightness (Lumens)	4000		
Light Source	UHP Lamp		
Light Source Life Maximum Hours	15000		
Maximum Supported Resolution	1920×1200		
Horizontal Sync. Range (KHz)	15 - 97.55		
Vertical Sync. Range (Hz)	54 - 85		
Uniformity (%)	80		
LENS			
Lens	1.1×		
Lens Zoom Adjustment	Manual		
Image Offset (%)	115		112.4
Focal Length (mm)	21.85 - 24.01		
F-Stop	2.41		
Keystone Adjustment	Manual/Automatic		
Vertical Keystone Correction	± 40°		
Projection Factor	1.94 - 2.16:1		1.54 - 1.72:1
Projection Distance (Meters/Feet)	1.2 - 12.0 / 3.94 - 39.36		1.0 - 10.0 / 3.28 - 32.80
Optical Zoom	1.1:1		
Digital Zoom Demagnification / Magnification	0.8× - 2.0×		
Focus Adjustment	Manual		
CONNECTIVITY—INPUTS			
Mini D-sub 15-pin (VGA)		<input checked="" type="checkbox"/>	
Composite Video		-	
S-Video		<input checked="" type="checkbox"/>	
HDMI™ 1.4		<input checked="" type="checkbox"/>	
RJ45 - LAN 10/100/1000		-	
3.5 mm Stereo Mini Jack		<input checked="" type="checkbox"/>	
CONNECTIVITY—OUTPUTS			
Mini D-sub 15-pin (VGA)		-	
3.5 mm Stereo Mini Jack		<input checked="" type="checkbox"/>	
Powered USB-A for Wireless Dongle		<input checked="" type="checkbox"/>	
CONNECTIVITY- OTHER			

	IN0002SL	IN0004SL	IN0006SL
RS232		-	
All Major 3D Formats		☑	
USB-A for Service		☑	
POWER			
Power Supply	100 - 240 V AC; 50 - 60 Hz		
Power Consumption Max (W)	267		
Power Consumption Min. (W)	210		
Power Consumption Network Standby (W)	<2.0		
Power Consumption Standby (W)	<0.5		
GENERAL			
Product Dimensions (L x W x H) (mm / in)	313 x 236 x 96.4 / 12.4 x 9.3 x 3.8		
Product Weight (Kilograms/Pounds)	2.9 / 6.4		
Packaged Dimensions (L x W x H) (mm / in)	395 x 337 x 166 / 15.6 x 13.3 x 6.5		
Packaged Weight (Kilograms/Pounds)	4.1 / 9.0		
Fan Noise (dB)	27		
Audio (W)	1 x 10		
Operating Temperature (Celsius/Fahrenheit)	5 - 40 / 41 - 104		
Operating Humidity (%)	10 - 85		
Max Operating Altitude (meters / feet)	3048 / 10000		
Storage Temperature (Celsius/Fahrenheit)	-10 - 60 / 14 - 140		
Storage Humidity (%)	10 - 85		
Security	Kensington Security Slot™, PIN Code Lock & Timer		
Safety and Regulatory	CB, CE, EAC, cTUVus, CCC, FCC, UKCA, NOM, PSB, BIS		
Environmental	WEEE, EU RoHS, China RoHS, CEL, CECP		
IN THE BOX			
Projector	☑	☑	☑
Simplified Users Guide	☑	☑	☑
VGA Cable	☑	☑	☑
Regional Power Cord	☑	☑	☑
Remote Control (no Battery)	☑	☑	☑

14.3 GENESIS IV, P125 & P126, SPECIFICATIONS

	IN0022SL	IN0024SL	IN0026SL	IN0028SL	IN0024ST	IN0026ST
IMAGE						
Product Series	GENESIS IV					
Display Technology	Texas Instruments DLP®					
Panel Size	0.55" DMD		0.65" DMD	0.47" DMD	0.55" DMD	0.65" DMD
Native Resolution	SVGA	XGA	WXGA	1080p	XGA	WXGA
Pixels	800×600	1024×768	1280×800	1920×1080	1024×768	1280×800
Aspect Ratio	4:3		16:10	16:9	4:3	16:10
Contrast Ratio	30000:1					
Brightness (Lumens)	4000				3800	
Light Source	UHP Lamp					
Light Source Life Maximum Hours	15000					
Maximum Supported Resolution	1920×1200					
Horizontal Sync. Range (KHz)	15 - 97.55					
Vertical Sync. Range (Hz)	54 - 85					
Uniformity (%)	80					
LENS						
Lens	1.1×				1:1 Fixed	
Lens Zoom Adjustment	Manual				-	
Image Offset (%)	115	112,4	116	115	112,4	
Focal Length (mm)	21.85 - 24.01				7,15	
F-Stop	2,41		2,1	2,7	2,8	
Keystone Adjustment	Manual/Automatic					
Vertical Keystone Correction	± 40°				± 20°	
Projection Factor	1.94 - 2.16:1	1.54 - 1.72:1	1.47 - 1.62:1	0.62:1	0.52:1	
Projection Distance (Meters/Feet)	1.2 - 12.0 / 3.94 - 39.36	1.0 - 10.0 / 3.28 - 32.80	1.0 - 9.8m / 3.28 - 32.14	0.4 - 3.76 / 1.31 - 12.33	0.4 - 3.37 / 1.31 - 11.05	
Optical Zoom	1.1:1			1:1		
Digital Zoom Demagnification / Magnification	0.8× - 2.0×					
Focus Adjustment	Manual					
CONNECTIVITY – INPUTS						
Mini D-sub 15-pin (VGA)	☑					
Composite Video	-					
S-Video	☑					
HDMI™ 1.4	☑☑					
RJ45 - LAN 10/100/1000	-					
3.5 mm Stereo Mini Jack	☑					
CONNECTIVITY – OUTPUTS						
Mini D-sub 15-pin (VGA)	☑					
3.5 mm Stereo Mini Jack	☑					
Powered USB-A for Wireless Dongle	☑					

	IN0022SL	IN0024SL	IN0026SL	IN0028SL	IN0024ST	IN0026ST
CONNECTIVITY- OTHER						
RS232				☑		
All Major 3D Formats				☑		
USB-A for Service				☑		
POWER						
Power Supply	100 - 240 V AC; 50 - 60 Hz					
Power Consumption Max (W)	267					
Power Consumption Min. (W)	210					
Power Consumption Network Standby (W)	<2.0					
Power Consumption Standby (W)	<0.5					
GENERAL						
Product Dimensions (L x W x H) (mm / in)	313 x 236 x 96.4 / 12.4 x 9.3 x 3.8					
Product Weight (Kilograms/Pounds)	2.9 / 6.4					
Packaged Dimensions (L x W x H) (mm / in)	395 x 337 x 166 / 15.6 x 13.3 x 6.5					
Packaged Weight (Kilograms/Pounds)	4.1 / 9.0					
Fan Noise (dB)	27					
Audio (W)	1 x 10					
Operating Temperature (Celsius/ Fahrenheit)	5 - 40 / 41 - 104					
Operating Humidity (%)	10 - 85					
Max Operating Altitude (meters / feet)	3048 / 10000					
Storage Temperature (Celsius/Fahrenheit)	-10 - 60 / 14 - 140					
Storage Humidity (%)	10 - 85					
Security	Kensington Security Slot™, PIN Code Lock & Timer					
Safety and Regulatory	CB, CE, EAC, cTUVus, CCC, FCC, UKCA, NOM, PSB, BIS					
Environmental	WEEE, EU RoHS, China RoHS, CEL, CECP					
IN THE BOX						
Projector	☑	☑	☑	☑	☑	☑
Simplified Users Guide	☑	☑	☑	☑	☑	☑
VGA Cable	☑	☑	☑	☑	☑	☑
Regional Power Cord	☑	☑	☑	☑	☑	☑
Remote Control (no Battery)	☑	☑	☑	☑	☑	☑

14.4 ORBITAL, P134, SPECIFICATIONS

IN0061SL	
IMAGE	
Product Series	ORBITAL
Display Technology	Texas Instruments DLP®
Panel Size	0.47" DMD
Native Resolution	4K UHD
Pixels	3840 x 2160
Aspect Ratio	16:9
Contrast Ratio	1000000:1
Brightness (Lumens)	4000
Light Source	UHP Lamp
Light Source Life Maximum Hours	15000
Maximum Supported Resolution	3840 x 2160
Horizontal Sync. Range (KHz)	15 - 150
Vertical Sync. Range (Hz)	24 - 240
Uniformity (%)	80
LENS	
Lens	1.3x
Lens Zoom Adjustment	Manual
Image Offset (%)	115
Focal Length (mm)	12.81 - 16.74
F-Stop	2.43
Keystone Adjustment	Manual/Automatic
Vertical Keystone Correction	± 30°
Projection Factor	1.21 - 2.59:1
Projection Distance (Meters/Feet)	1.0 - 8.1 / 3.2 - 26.6
Optical Zoom	1.3:1
Digital Zoom Demagnification / Magnification	0.8x - 2.0x
Focus Adjustment	Manual
CONNECTIVITY—INPUTS	
Mini D-sub 15-pin (VGA)	☑
Composite Video	—
S-Video	—
HDMI™ 2.0 (HDCP 2.2)	☑☑
RJ45 - LAN 10/100/1000	—
3.5 mm Stereo Mini Jack	☑
CONNECTIVITY—OUTPUTS	
Mini D-sub 15-pin (VGA)	—
3.5 mm Stereo Mini Jack	☑
Powered USB - A 5v 1.5A	☑
S/PDIF Optical Audio	☑

IN0061SL	
CONNECTIVITY- OTHER	
RS232	<input checked="" type="checkbox"/>
All Major 3D Formats	<input checked="" type="checkbox"/>
POWER	
Power Supply	100 - 240 V AC; 50 - 60 Hz
Power Consumption Max (W)	300
Power Consumption Min. (W)	210
Power Consumption Network Standby (W)	-
Power Consumption Standby (W)	<0.5
GENERAL	
Product Dimensions (L x W x H) (mm / in)	313 x 234 x 96.4 / 12.4 x 9.2 x 3.8
Product Weight (Kilograms/Pounds)	3.2 / 7.0
Packaged Dimensions (L x W x H) (mm / in)	400 x 337 x 168 / 15.7 x 13.3 x 6.6
Packaged Weight (Kilograms/Pounds)	4.4 / 9.7
Fan Noise (dB)	27
Audio (W)	1 x 10
Operating Temperature (Celsius/Fahrenheit)	0 - 40 / 32 - 104
Operating Humidity (%)	10 - 80
Max Operating Altitude (meters / feet)	3048 / 10000
Storage Temperature (Celsius/Fahrenheit)	-20 - 60 / -4 - 140
Storage Humidity (%)	10 - 80
Security	Kensington Security Slot™, PIN Code Lock & Timer
Safety and Regulatory	CB, CE, EAC, cTUVus, CCC, FCC, UKCA
Environmental	WEEE, EU RoHS, China RoHS
IN THE BOX	
Projector	<input checked="" type="checkbox"/>
Simplified Users Guide	<input checked="" type="checkbox"/>
HDMI Cable	<input checked="" type="checkbox"/>
Regional Power Cord	<input checked="" type="checkbox"/>
Remote Control (no Battery)	<input checked="" type="checkbox"/>

15.1 FOR USERS IN THE UNITED STATES



INFORMATION

FCC COMPLIANCE STATEMENT – CLASS B

This equipment generates, uses and can radiate radio frequency energy, and if not installed and used in accordance with the instruction manual may cause interference to radio communications. It has been tested and found to comply with the limits for a Class “B” computing device pursuant to Subpart B of Part 15 of the FCC Rules, which are designed to provide reasonable protection against such interference when operated in a residential installation. However, there is no guarantee that interference will not occur in a particular installation. If this product does cause harmful interference to radio or television reception, or any other form of communication, the user is encouraged to try to correct the interference by one or more of the following measures:

- Reorient or relocate the receiving antenna.
- Increase the separation between the product and receiver.
- Connect the product to an outlet on a circuit different from that to which the receiver is connected.
- Consult the dealer or an experienced radio/TV technician for help.

Any changes or modifications not expressly approved by the party responsible for compliance may void the user’s authority to operate the product. Where shielded interface cables have been provided with the product, specified additional components or accessories elsewhere defined to be used with the installation of the product, they shall be used in order to ensure compliance with FCC regulations.

US Importer and Local Representative in accordance with FCC regulations

Maxnerva Technology Services USA LLC
13190 SW 68th Parkway, Suite 120
Portland, Oregon 97223.

15.2 FOR USERS IN CANADA



INFORMATION

This Class B digital apparatus complies with Canadian ICES-003.
Cet appareil numérique de la classe B est conforme la norme NMB-003 du Canada.

INDUSTRY CANADA REGULATORY INFORMATION

Operation is subject to the following two conditions:

- (*1) this device may not cause interference, and
- (*2) this device must accept any interference, including interference that may cause undesired operation of the device.

The user is cautioned that this device should be used only as specified within this manual to meet RF exposure requirements. Use of this device in a manner inconsistent with this manual could lead to excessive RF exposure conditions.

INSTRUCTIONS TO USERS: This equipment complies with the requirements of FCC equipment provided that the following conditions are met. If the cables include a EMI ferrite core, attach the ferrite core end of the cable to the projector. Use the cables which are included with the projector or specified.

** Changes or modifications not expressly approved by the party responsible for compliance could void the user’s authority to operate the equipment.

Complies with IDA Standards DA103121

15.3 FOR USERS IN EUROPEAN UNION



INFORMATION
EU COMPLIANCE



INFORMATION
CE COMPLIANCE STATEMENT

Electromagnetic Compatibility Statement: Meets 2014/30/EU Directive
Low Voltage Directive: Meets 2014/35/EU Directive

EU Importer

Grand Field Technology Limited
Room 1001, 10/F, Houston Centre, 63 Mody Road, Tsim Sha Tsui East, Kowloon, Hong Kong.

EU Authorised Representative

24hour Solutions B.V.
Van Nelleweg 1,
3044 BC, Rotterdam,
The Netherlands
info@24hour-ar.com
www.24hour-ar.com

15.4 FOR USERS IN THE UNITED KINGDOM AND NORTHERN IRELAND



INFORMATION
UK COMPLIANCE



INFORMATION
UKCA COMPLIANCE STATEMENT

Electromagnetic Compatibility Regulations 2016
Electrical Equipment (Safety) Regulations 2016
The Restriction of the Use of Certain Hazardous Substances in Electrical and Electronic Equipment Regulations 2012
Manufacturer, Importer and Authorised Representative in accordance with notational directives

Manufacturer

Maxnerva Technology Services Limited
Room 1001, 10/F, Houston Centre, 63 Mody Road, Tsim Sha Tsui East, Kowloon, Hong Kong.

UK Authorised Representative in accordance with UK regulations

24hour Solutions Ltd.
15 Beaufort Court
Admirals Way, Canary Wharf
London, E14 9XL, UK
+44 (0)20 457 129 06
Company ID 13630765

15.5 FOR USERS IN RUSSIA



INFORMATION

Russian Authorised Representative

Maxnerva has appointed AUVIX LLC, 129085, c. Moscow, Zvezdny Boulevard, 21, bldg. 1. as the authorised representative in Russia and this product is compliant with TR TC 004/2011, TR TC 020/2011 and TR CU 020/2011 local conformity testing and approvals.

Maxnerva назначил ООО « АУВИКС », 129085, г. Москва, Звездный бульвар, д. 21, стр. 1., в качестве официального представителя в России, и этот продукт соответствует требованиям TR TC 004/2011, TR TC 020/2011 и TR CU 020 /2011г. местные испытания на соответствие и согласования.

ООО « АУВИКС »

129085, г. Москва, Звездный бульвар, д. 21, стр. 1

+7 (495) 797-57-75

info@auvix.ru