

n **Vf**
PAGE
284-285

**OSAWA
NORM**

Ø mm	3-20
tol. D µ	0 / -30
tol. R µ	±20

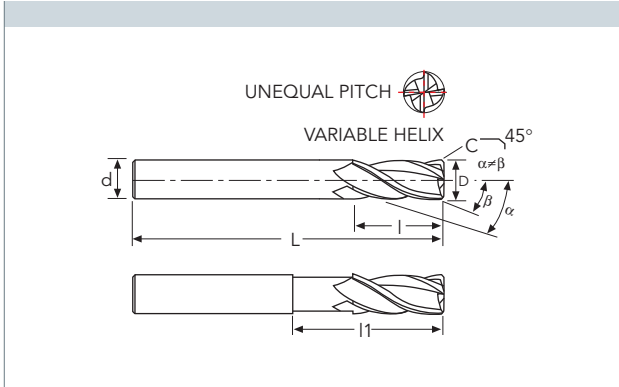

MG	MG	MG	MG	MG	MG
PV300	PV300	PV300	PV300	PV300	PV300
HF UNI	HF UNI	HF UNI	HF HARD	HF HARD	HF HARD

D	C (45°)	d(h6)	l	l1	L	Stock	Stock	Stock	Stock	Stock	Stock
mm 3	0,1	6	9		57	●				●	
	0,1	6	9	15	57		●				●
4	0,1	6	11		57	●				●	
	0,1	6	11	20	57		●				●
5	0,1	6	13		57	●				●	
	0,1	6	13	20	57		●				●
6	0,1	6	13		57	●				●	
	0,1	6	13	20	57		●				●
8	0,2	8	20		64	●				●	
	0,2	8	20	26	64		●				●
10	0,2	10	22		72	●				●	
	0,2	10	22	30	72		●				●
12	0,2	12	26		83	●				●	
	0,2	12	26	36	83		●				●
14	0,3	14	26		83	●				●	
	0,3	14	26	36	83		●				●
16	0,3	16	32		92	●				●	
	0,3	16	32	42	92		●				●
18	0,3	18	32		92	●				○	
	0,3	18	32	42	92		○				
20	0,4	20	38		104	●				●	
	0,4	20	38	50	104		●				●

● stock standard ○ non-standard stock ■ stock exhaustion

- TYPHOON
- C-SD-TA
- LFTA
- SUTA
- HSS-HSS/CO DRILLS
- UH RED
- MEX ORANGE
- HF EVO
- MEF ENDLESS
- ALU
- MDC
- G2
- MDTA
- ULTRA MILLS
- HSS/CO
- CARBIDE BURRS
- PARAMETERS